

事務連絡
令和4年3月15日

各都道府県衛生主管部（局）薬務主管課 御中

厚生労働省医薬・生活衛生局医薬品審査管理課

生理処理用品材料規格の英訳について

医薬部外品のうち、生理処理用品の材料規格については、「生理処理用品材料規格について」（令和3年6月28日付け薬生薬審発0628第16号厚生労働省医薬・生活衛生局医薬品審査管理課長通知）により示してきたところですが、別添のとおり、当該規格の英訳を作成したのでお知らせいたします。

なお、本事務連絡の発出に伴い、「生理処理用品材料規格の英訳について」（平成27年11月19日付け厚生労働省医薬・生活衛生局審査管理課事務連絡）は廃止します。

Provisional Translation
From Japanese Original

June 28, 2021

Notification PSEHB/PED No.0628-16

The Japanese Specifications of Sanitary Napkin Materials

<1. General Notices>

1. This standard is entitled “The Japanese Specifications of Sanitary Napkin Materials” and may be abbreviated as “JSNM”. The napkin materials generally used are listed in Part 1 and the colorants are listed in Part 2.
2. The specifications and test methods shall be in accordance with the General Notices and the General Tests, Processes and Apparatus of the Japanese Pharmacopoeia when they are not specified in the General Notices, General Tests, Processes and Apparatus, and Monographs of the JSNM. The Japanese Pharmacopoeia (hereinafter referred to as JP) is specified in the Law for Ensuring the Quality, Efficacy, and Safety of Drugs and Medical Devices (Law No. 145, 1960) and the Japanese Industrial Standards (herein after referred to as JIS) are specified in the Industrial Standardization Act (Law No. 185, 1949).
3. The commonly used name and English name are indicated after the title of the napkin material in each monograph, as appropriate.
4. Napkin materials are to be tested according to the provisions given in the pertinent monographs, General Notices, and General Tests for their conformity to JSNM.
5. The molecular formula is additionally indicated in parentheses after the chemical name. Atomic masses adopted in JSNM conform to the table of “Standard Atomic Weights 2004”. Molecular masses are indicated to two decimal places rounded from three decimals.

6. The following abbreviations are used for the principal units. The SI system is used for other units.

Meter	m	Centimeter	cm	Millimeter	mm
micrometer	μm	Nanometer	nm	per centimeter	cm ⁻¹
ton	t	Kilogram	kg	Gram	g
milligram	mg	Microgram	μg	Liter	L
milliliter	mL	Microliter	μL	square centimeter	cm ²
kilopascal	kPa	mole per liter	mol/L		

7. The signs “%,” “w/v%,” “vol%,” and “v/w%” are used for mass per cent, mass per volume per cent, volume per cent, and volume per mass per cent, respectively. “ppm” usually indicates mass parts per million.
8. The temperature is expressed in Celsius degree as Arabic numerals followed by °C.

9. Standard temperature, ordinary temperature, room temperature, and lukewarm are defined as 20°C, 15-25°C, 1-30°C, and 30-40°C, respectively. A cold place, unless otherwise specified, shall be a place having a temperature not exceeding 15°C. The temperature of cold water, lukewarm water, warm water, and hot water are defined as not exceeding 10°C, 30-40°C, 60-70°C, and about 100°C, respectively. The term “heated solvent” or “hot solvent” means a solvent heated almost to the boiling point of the solvent, and the term “warmed solvent” or “warm solvent” usually means a solvent heated to a temperature between 60°C and 70°C. The term “heat on or in a water bath” indicates, unless otherwise specified, heating with a boiling water bath or a steam bath at about 100°C.

10. To measure the number of drops, a dropping device which delivers 20 drops of Purified Water (JP) weighing 0.90-1.10 g at 20°C shall be used.

11. The term “in vacuum” indicates, unless otherwise specified, a pressure not exceeding 2.0 kPa.

12. The acidity or alkalinity of a solution, unless otherwise specified, is determined by blue or red litmus papers. To indicate these properties more precisely, pH values are used. Such expressions as “slightly acidic”, “weakly/mildly acidic”, “strongly acidic”, “slightly alkaline”, “weakly/mildly alkaline” and “strongly alkaline” indicate approximate degrees of acidity or alkalinity, which respectively correspond to the following pH ranges:

	pH range (approx.)		pH range (approx.)
Slightly acidic	5-6.5	Slightly alkaline	7.5-9
Weakly acidic	3-5	Weakly alkaline	9-11
Strongly acidic	Not more than 3	Strongly alkaline	Not less than 11

13. Unless otherwise specified, the matching fluids for color, reagents, test solutions, standard solutions, standard solutions for volumetric analysis, reference standards, measuring instruments and appliances to be used in the General Notices, General Tests and monographs of JSNM shall be those specified in the General Tests. Unless otherwise specified, the water to be used in the tests shall be Purified Water (JP).

14. As for wording “solution”, where the name of the solvent is not stated, the term “solution” indicates a solution in water.

15. For solution an expression such as “(1 in 3)”, “(1 in 10)”, or “(1 in 100)” means that 1 g of a solid is dissolved in, or 1 mL of a liquid is diluted with the solvent to make the total volume of 3 mL, 10 mL or 100 mL, respectively. For the liquid mixture an expression such as “(10:1)” or “(5:3:1)” means that the respective numbers of parts, by volume, of the designated liquids are to be mixed.

16. The term “weigh accurately” means to weigh down to the degree of 0.1 mg, 0.01 mg or 0.001 mg by

taking into account the purpose of the test and using a relevant weighing device. The term “weigh exactly” means to weigh to the given decimal places.

17. A value of “n” figures in a test of a napkin material shall be obtained by rounding off a value of “n+1” figures.
18. Unless otherwise specified, all tests of the napkin materials shall be performed at the ordinary temperature and observations of the results shall follow immediately after the operations. However, the judgment for a test which is affected by temperature should be based on the conditions at the standard temperature.
19. The term “description” in the monograph states the color, shape, and odor of the napkin material as a reference. In the section under the heading Description, the term “white” is used to indicate white or practically white. Unless otherwise specified, the test of color is carried out by placing 1 g of a solid material on a sheet of white paper or in a watch glass placed on white paper. A liquid material is put into a colorless test tube of 15-mm internal diameter and is observed in front of a white background through a layer of 30 mm. The term “odorless” is used to indicate odorless or practically odorless. Unless otherwise specified, the test of odor shall be carried out by placing about 1 g of a solid material or about 1 mL of a liquid material in a 100-mL beaker.
20. “Identification” is the test necessary to identify the specific component(s) of a napkin material based upon its specific property.
21. “Characteristic value” is to test the characteristics of a napkin material, generally is to specify its physicality, state, and the range of composition.
22. “Purity” is the test to detect impurities/contaminants in napkin materials, and it, as well as other requirements in each monograph, specifies the purity of the material usually by limiting the kind/nature and quantity of the impurities/contaminants. The impurities/contaminants subject to the purity test are those supposed to generate/contaminate during the manufacturing process or storage, including hazardous agents such as heavy metals, arsenic, etc. In the fluorescence test of a material, the term “marked fluorescence” indicates that the fluorescence of the material is more intense than Fluorescence Reference Standard and has a certain extensity partially.
23. In the test of a napkin material, the term “dissolve” or “miscible” indicates that it dissolves in, or mixes in arbitrary proportion with the solvent to form a clear solution or mixture. Insoluble materials other than the material including fibers should not be detected or practically invisible, if any.

24. In the test of a napkin material, the terms “immerse”, “macerate” and “perform cold extraction”, mean that the material is to be soaked in water for at least 5 minutes. unless solvent specified,
25. The term “constant mass” in drying or ignition, means that the mass difference after an additional 1 hour of drying or ignition is not more than 0.10% of the preceding mass of the dried substance or ignited residue. However, when the difference does not exceed 0.5 mg in a chemical balance, 0.05 mg in a semi-microbalance, or 0.005 mg in a microbalance, the difference is regarded as negligible and constant mass has been attained.
26. In stating the sample quantity to be taken, the use of the word “about” indicates a quantity within 10% of the specified mass.
27. The test methods specified in JSNM may be selected on the basis of the characteristics of the napkin material.
28. Alternative test methods which are better than the test methods specified in JSNM in precision and accuracy can be substituted. However, where a difference is suspected in test results, the procedure given in the JSNM is followed for the final judgment.

<2. General Tests, Processes and Apparatus>

- 1. Acrylic Unreacted Monomer Test**
- 2. Liquid Chromatography**
- 3. Chloride Limit Test**
- 4. Flame Coloration Test (for Metallic Salts)**
- 5. Total Ash Test**
- 6. Gas Chromatography**
- 7. Loss on Drying Test**
- 8. Ultraviolet-visible Spectrophotometry (Former name: Spectrophotometry)**
- 9. Residue on Ignition Test**
- 10. Saponification Value Determination**
- 11. Atomic Absorption Spectrophotometry**
- 12. Acid Value Determination**
- 13. Heavy Metals Limit Test**
- 14. Infrared Spectrophotometry**
- 15. Qualitative Tests**
- 16. Viscosity Determination**
- 17. pH Determination**
- 18. Determination of Specific Gravity and Density**
- 19. Arsenic Limit Test**
- 20. Melting Point Determination**
- 21. Readily Carbonizable Substances Test**
- 22. Standard Solutions, Matching Fluids for Color, Reference Standards, Reagents, Test Solutions, Measuring Instruments and Appliances**

1. Acrylic Unreacted Monomer Test

Acrylic Unreacted Monomer Test is a method to measure the unreacted monomer with double bonds mainly in an acrylic sample.

Procedure

Unless otherwise specified, weigh accurately the amount of sample conforming to the monograph, in a 300-mL iodine flask. Add 100 mL of water and stir for 1 hour for dispersion. To the solution add exactly 5 mL of potassium bromate-potassium bromide TS with stirring, add quickly 20 mL of diluted hydrochloric acid (1 in 4), and stopper immediately and tightly. Place 10 mL of potassium iodide TS on the upper stopper of the iodine flask, and allow to stand in a dark place for 20 minutes while shaking occasionally. Take out the iodine flask from a dark place, pour potassium iodide TS placed on the upper stopper into the flask, immediately stopper tightly, and shake sufficiently. Use the solution as the sample solution and titrate with 0.1 mol/L sodium thiosulfate VS (indicator: 2 mL of starch TS) until the color of the sample solution changes from deep purple to colorless, and titrate by continuous shaking for 10 minutes until no color develops again. Separately, perform a blank determination, and calculate the content of unreacted monomer from the following equation.

$$\text{Content (\% of unreacted monomer)} = \frac{0.0047(a-b)}{c} \times 100(\%)$$

a: Volume (mL) of 0.1 mol/L sodium thiosulfate VS consumed in a blank determination

b: Volume (mL) of 0.1 mol/L sodium thiosulfate VS consumed of the sample

c: Amount (g) of sample

2. Liquid Chromatography

Liquid Chromatography is a method to develop a mixture injected into a column prepared with a suitable stationary phase by passing a liquid as a mobile phase through the column, in order to separate the mixture into its components by making use of the difference of retention capacity against the stationary phase, and to determine the components. This method can be applied to a liquid or soluble sample, and is used for identification, purity test, and quantitative determination.

A mixture injected into the column is distributed between the mobile phase and the stationary phase with a characteristic ratio (k) for each component.

$$k = \frac{\text{amount of compound in the stationary phase}}{\text{amount of compound in the mobile phase}}$$

The ratio k represents the mass distribution ratio (or the capacity factor) k' in liquid chromatography.

Since the relation given below exists among the ratio (k), the time for which the mobile phase is passed through the column (t_0 : time measured from the time of injection of a compound with $k=0$ to the time of elution at the peak maximum), and the retention time (t_R : time measured from the time of injection of a compound to be determined to the time of elution at the peak maximum), the retention time for a compound on

a column has a characteristic value under fixed chromatographic conditions.

$$t_R = (1 + k) t_0$$

Apparatus

Basically, the apparatus required for the liquid chromatographic procedure consists of a pumping system for the mobile phase, a sample injection port, a column, a detector and a recorder. A mobile phase component regulator, a thermostat for the column, a pumping system for reaction reagents and a chemical reaction chamber are also used, if necessary. The pumping system serves to deliver the mobile phase and the reagents into the column and connecting tube at a constant flow rate. The sample injection port is used to deliver a quantity of the sample to the apparatus with high reproducibility. The column is a tube with a smooth interior, made of inert metal, etc., in which a packing material for liquid chromatography is uniformly packed. A column with a stationary phase chemically bound on the inside wall instead of the column packed with the packing material may be used. The detector is used to detect a property of the samples which is different from that of the mobile phase, and may be an ultraviolet or visible spectrophotometer, fluorometric detector, differential refractometer, electrochemical detector, chemiluminescence detector, electric conductivity detector, mass spectrophotometer, etc. The output signal is usually proportional to the concentration of samples at amounts of less than a few μg . The recorder is used to record the output signals of the detector. As required, a data processor may be used as the recorder to record or output the chromatogram, retention times, or amounts of the components. The mobile phase component regulator is used to vary the ratio of the mobile phase components in a stepwise or gradient fashion.

Procedure

Fix the detector, column and mobile phase to the apparatus, and adjust the flow rate and the column temperature to the values described in the operating conditions specified in the individual monograph. Inject a volume of the sample solution or the standard solution specified in the individual monograph with the sample injector into the column through the sample injection port. The separated components are detected by the detector, and recorded by the recorder as a chromatogram. If the components to be analyzed have no readily detectable physical properties such as absorbance or fluorescence, the detection is achieved by changing the components to suitable derivatives. Usually, the derivatization is performed as a pre- or post-column labeling.

Identification and purity test

Identification of a component of a sample is performed by confirming agreement of the retention time of the sample with that of an authentic specimen, or by confirming that the peak shape of the sample is unchanged after mixing the sample with an authentic specimen.

In general, the purity of the sample is determined by comparing the sample solution with a standard solution, which is prepared by diluting the sample solution to a concentration corresponding to the specified limit amount of the impurity, or by the peak area percentage method. Unless otherwise specified, if a sample is separated into isomers in the chromatogram, the isomer ratio is calculated by using the peak area percentage method.

The peak area percentage method is a method to calculate the proportion of the components from the ratio of the peak area of each component to the sum of the peak areas of every peak recorded in the chromatogram. In order to obtain accurate results in evaluating the proportion of the components, it is necessary to correct the

area of each component based on the relative sensitivity to the principal component.

3. Chloride Limit Test

Chloride Limit Test is a limit test for chloride contained in a sample. In each monograph, the permissible limit for chloride (as Cl) is described in terms of percentage (%) in parentheses.

Procedure

Unless otherwise specified, transfer the quantity of the sample, directed in the monograph, to a Nessler tube, dissolve it in sufficient water, and add water to make 40 mL. Add 6 mL of dilute nitric acid and water to make 50 mL, and use this solution as the sample solution. Transfer the volume of 0.01 mol/L hydrochloric acid VS, directed in the monograph, to another Nessler tube, add 6 mL of dilute nitric acid and water to make 50 mL, and use this solution as the control solution. When the sample solution is not clear, filter both solutions according to the same procedure.

Add 1 mL of silver nitrate TS to the sample solution and to the control solution, mix well, and allow to stand for 5 minutes protecting from direct sunlight. Compare the opalescence developed in both solutions against a black background by viewing downward or transversely.

The turbidity produced in the sample solution is not thicker than that of the control solution.

4. Flame Coloration Test (for Metallic Salts)

Flame Coloration Test is a method to detect an element, by means of the property that the element changes the colorless flame of a Bunsen burner to its characteristic color.

Procedure

The platinum wire used for this test is about 0.8 mm in diameter, and the end part of it is straight. In the case of a solid sample, make the sample into a gruel by adding a small quantity of hydrochloric acid, apply a little of the gruel to the 5-mm end of the platinum wire, and test by putting the end part in a colorless flame, keeping the platinum wire horizontal. In the case of a liquid sample, immerse the end of the platinum wire into the sample to about 5 mm in length, remove from the sample gently, and perform the test in the same manner as for the solid sample.

5. Total Ash Test

Total Ash Test is a method to measure the total amount of ash in a sample.

Procedure

Ignite previously a crucible of platinum, quartz or porcelain between 500°C and 550°C for 1 hour. Cool, and

weigh accurately the crucible. Unless otherwise specified, weigh accurately 2 to 4 g of the test sample for analysis in this crucible, take off the lid or keep it open a little if necessary, heat the crucible at a low temperature at first, then gradually heat to a temperature between 500°C and 550°C, ignite to incinerate the residue for more than 4 hours until no carbonized substance remains in the ash, cool and weigh accurately the ash. Incinerate repeatedly to constant mass, cool, weigh accurately, and determine the amount (%) of total ash. If a carbonized substance remains and a constant mass cannot be obtained in the above-mentioned method, extract the charred mass with hot water, collect the insoluble residue on filter paper for assay, and incinerate the residue and filter paper until no carbonized substance remains in the ash. Then add the filtrate, evaporate it to dryness, and incinerate. Cool, weigh accurately, and determine the mass (%) of the total ash. If a carbon-free ash cannot be obtained even in this way, moisten the ash with a small amount of ethanol (95), break up the ash with a glass rod, wash the rod with a small amount of ethanol (95), evaporate carefully, and determine the mass of the total ash as described above. A desiccator (silica gel) is used for cooling.

6. Gas Chromatography

Gas Chromatography is a method to develop a mixture injected into a column prepared with a suitable stationary phase by passing a gas (carrier gas) as a mobile phase through the column, in order to separate the mixture into its components by making use of the difference of retention capacity against the stationary phase, and to determine the components. This method can be applied to a gaseous or vaporizable sample, and is used for identification, and purity test.

A mixture injected into the column is distributed between the mobile phase and the stationary phase with a characteristic ratio (k) for each component.

$$k = \frac{\text{amount of compound in the stationary phase}}{\text{amount of compound in the mobile phase}}$$

Since the relation given below exists among the ratio (k), the time for which the mobile phase is passed through the column (t_0 : time measured from the time of injection of a compound with $k=0$ to the time of elution at the peak maximum), and the retention time (t_R : time measured from the time of injection of a compound to be determined to the time of elution at the peak maximum), the retention time for a compound on a column has a characteristic value under fixed chromatographic conditions.

$$t_R = (1+k) t_0$$

Apparatus

Basically, the apparatus required for the gas chromatographic procedure consists of a carrier gas-introducing port and flow regulator, a sample injection port, a column, a column oven, a detector and a recorder. Gas introducing port and flow regulator for a combustion gas, a burning supporting gas and an accessory gas and sample injection port for headspace are also used, if necessary.

The carrier gas-introducing port and flow regulator serves to deliver the carrier gas into the column at a constant flow rate, and usually consist of a pressure regulation valve, a flow rate regulation valve and a

pressure gauge. The sample injection port is used to deliver a quantity of the sample to the flow line of carrier gas with high reproducibility. There are sample injection ports for packed column and for capillary column. There are both divided injection mode and non-divided injection mode to sample injection port for capillary column. The columns are usually classified as packed column or capillary column. The packed column is a tube made of inert metal, glass or synthetic resin, in which a packing material for gas chromatography is uniformly packed. The packed column with not more than 1mm in inside diameter is also called a packed capillary column (micro packed column). A capillary column is a tube made of inert metal, glass, quartz or synthetic resin, whose inside wall is bound chemically with stationary phase for gas chromatography. The column oven has the setting capacity for a column with required length and the temperature regulation system for keeping the constant column temperature. The detector is used to detect a component separated on the column, and may be an alkaline thermal ionization detector, a flame photometry detector, mass spectrophotometer, hydrogen flame-ionization detector, an electron capture detector, a thermal conductivity detector, etc. The recorder is used to record the output signals of the detector.

Procedure

Unless otherwise specified, proceed by the following method. Fix the detector, column and carrier gas to the apparatus, and adjust the flow rate and the column temperature to the values described in the operating conditions specified in the individual monograph. Inject a volume of the sample solution or the standard solution specified in the individual monograph with the sample injector into the system. The separated components are detected by the detector, and recorded by the recorder as a chromatogram.

Identification and purity test

Identification of a component of a sample is performed by confirming agreement of the retention time of the sample with that of an authentic specimen, or by confirming that the peak shape of the sample is unchanged after mixing the sample with an authentic specimen.

In general, the purity of the sample is determined by comparing the sample solution with a standard solution, which is prepared by diluting the sample solution to a concentration corresponding to the specified limit amount of the impurity, or by the peak area percentage method.

The peak area percentage method is a method to calculate the proportion of the components from the ratio of the peak area of each component to the sum of the peak areas of every peak recorded in the chromatogram. In order to obtain accurate results in evaluating the proportion of the components, it is necessary to correct the area of each component based on the relative sensitivity to the principal component.

7. Loss on Drying Test

Loss on Drying Test is a method to measure the loss in mass of the sample, when dried under the conditions specified in the monograph. This method is applied to determine the amount of water, all or a part of water of crystallization, or volatile matter in the sample, which is removed during the drying.

The description, for example, not more than 1.0% (1 g, 105°C, 4 hours) in the monograph, indicates that the

loss in mass is not more than 10 mg per 1 g of the substance in the test in which about 1 g of the substance is accurately weighed and dried at 105°C for 4 hours, and not more than 0.5% (1 g, in vacuum, phosphorus (V) oxide, 4 hours), indicates that the loss in mass is not more than 5 mg per 1 g of the substance in the test in which about 1 g of the substance is accurately weighed, transferred into a desiccator (phosphorus (V) oxide), and dried in vacuum for 4 hours.

Procedure

Weigh accurately a weighing bottle that has been dried for 30 minutes according to the method specified in the monograph. Take the sample within the range of $\pm 10\%$ of the amount, directed in the monograph, transfer into the weighing bottle, and, unless otherwise specified, spread the sample so that the layer is not thicker than 5 mm, then weigh it accurately. Place the loaded bottle in a drying chamber, and dry under the conditions specified in the monograph. When the size of the sample is large, convert it to small particles having a size not larger than 2 mm in diameter by quick crushing, and use the crushed sample for the test. After drying, remove from the drying chamber, and reweigh accurately. When the sample is dried by heating, the temperature is within the range of $\pm 2^\circ\text{C}$ of that, directed in the monograph, and, after drying the bottle, the sample is allowed to cool in a desiccator (silica gel) before weighing.

If the sample melts at a temperature lower than that specified in the monograph, expose the sample for 1 to 2 hours to a temperature between 5°C and 10°C below the melting temperature, dry under the conditions specified in the monograph. Use a desiccant specified in the monograph, and renew frequently.

8. Ultraviolet-visible Spectrophotometry (Former name: Spectrophotometry)

Ultraviolet-visible Spectrophotometry is a method to measure the degree of absorption of light between the wavelengths of 200 nm and 800 nm by substances for the tests of their identity and purity and for assay. When an atomic absorption spectrophotometer is used for these purposes, proceed as directed under Atomic Absorption Spectrophotometry.

When monochromatic light passes through a substance in the solution, the ratio of transmitted light intensity I to incident light intensity I_0 is called transmittance t ; transmittance expressed in the a percentage is called percent transmission T , and common logarithm of the reciprocal of transmittance is called absorbance A .

$$t = \frac{I}{I_0} \quad T = \frac{I}{I_0} \times 100 = 100t \quad A = \log \frac{I_0}{I}$$

The absorbance A is proportional to the concentration c of a substance in the solution and the length l of the layer of the solution through which light passes.

$$A = kcl \quad (k = \text{constant})$$

The absorbance, calculated on the basis that l is 1 cm and c is 1 mol/L, is called molar absorption coefficient ϵ . The molar absorption coefficient at the wavelength of maximum absorption is expressed as ϵ_{max} .

When a light beam passes through a substance in the solution, the absorbance by the sample differs depending on the wavelength of the light. So, an absorption spectrum is obtained by determining the absorbances of a light beam at various wavelengths and by graphically plotting the relation between absorbance and

wavelength. From the absorption spectrum, it is possible to determine the wavelength of maximum absorption λ_{\max} and that of minimum absorption λ_{\min} . The absorption spectrum of a substance in the solution is characteristic, depending on its chemical structure. Therefore, it is possible to identify a substance by comparing the spectrum of a sample within the specified wavelength range with the Reference Spectrum or the spectrum of Reference Standard, by determining the wavelengths of maximum absorption, or by measuring the ratio of absorbances at two specified wavelengths. For the purpose of assay, the absorbance by a sample solution with a certain concentration is measured at the wavelength of the maximum absorption λ_{\max} and compared it with the absorbance of a standard solution with a certain concentration.

Apparatus and adjustment

A spectrophotometer or a photoelectric photometer is used for the measurement of absorbance.

After adjusting the spectrophotometer or photoelectric photometer based on the operation manual of the apparatus, it should be confirmed that the wavelength and the transmission rate meet the specifications of the tests described below.

The calibration of wavelength should be carried out as follows. Using an optical filter for wavelength calibration, measure the transmission rate in the vicinity of the standard wavelength value shown in the test results form, under the test conditions given in the test results form attached to each of the filters. When performing a test to determine the wavelength which shows minimal transmission rate, the difference between the measured wavelength and the standard wavelength value should be within ± 0.5 nm. When the measurement is repeated three times, each value obtained should be within the mean ± 0.2 nm. It is also possible to carry out the test using a low-pressure mercury lamp at bright line wavelengths of 253.65 nm, 365.02 nm, 435.84 nm and 546.07 nm, or a deuterium discharge lamp at bright line wavelengths of 486.00 nm and 656.10 nm. In the case of these tests, the difference between the measured wavelength and the wavelength of the bright line should be within ± 0.3 nm. When the measurement is repeated three times, each value obtained should be within the mean ± 0.2 nm.

The calibration of transmission rate or absorbance should be carried out as follows. Using an optical filter for transmission rate calibration, determine the transmission rate at the standard wavelength value under the test conditions given in the test results form attached to each of the filters. The difference between the measured transmission rate and the standard transmission rate value should be within the range of from 1% larger of the upper limit to 1% smaller of the lower limit for the relative accuracy shown in the test results form. When the measurement is repeated three times, each absorbance obtained (or calculated from the transmission rate) should be within the mean ± 0.002 when the absorbance is not more than 0.500, and within the mean ± 0.004 when the absorbance is more than 0.500. In addition, it will be desirable to confirm the linearity of transmission rate at the same wavelength using several optical filters for calibration of transmission rate with different transmission rates.

Procedure

After adjusting the apparatus as directed in the Apparatus and adjustment, select and set the light source, detector, mode of measurement, measuring wavelength or wavelength range, spectrum width, and scanning speed. Subsequently, allow the apparatus to stand for a certain time to confirm its stability. Then, usually adjust

the apparatus so that the transmittance is 0% at measuring wavelength or over measuring wavelength range after shutting the sample side of light path. Then open the shutter and adjust the transmittance to 100% (the absorbance is zero).

Adjusting the transmittance to 100% is usually done by putting cells containing the control solution in both light paths.

For the control solution, unless otherwise specified, blank solvent is used.

Then perform the measurement with the cell containing the sample solution and read the absorbance at measuring wavelength, or measure the spectrum over measuring wavelength range.

Unless otherwise specified, a cell with a path length of 1 cm, made of quartz for ultraviolet range and of quartz or glass for visible range, is used. Special consideration is needed with the absorption of solvents in the ultraviolet range; use a solvent which does not disturb accurate measurement.

Specific absorbance

The absorbance, calculated on the basis that l is 1 cm and c (concentration of a material) is 1 w/v%, is called specific absorbance, and is expressed as $E_{1cm}^{1\%}$.

$$E_{1cm}^{1\%} = \frac{A}{c \times l}$$

l : Length of the layer of the solution (cm)

A : Absorbance value

c : Concentration of the sample in the solution (w/v%)

The description of, for example, $E_{1cm}^{1\%}$ (241 nm): 500 – 530 (after drying, 2 mg, methanol, 200 mL) in the monograph, indicates that observed $E_{1cm}^{1\%}$ value is between 500 and 530, when the test is performed in the following manner. The sample is dried under the conditions specified in the Test for Loss on Drying, and about 2 mg of the sample is weighed accurately with a microbalance, and dissolved in methanol to make exactly 200 mL, then the absorbance of the solution is measured as directed in the Procedure at a wavelength of 241 nm using a cell with a path length of 1 cm.

Identification using absorption wavelength and limit test for contaminants

When maximum absorption wavelengths of the spectrum obtained from the sample solution match the wavelengths specified in the monograph, the identity of the substance may be confirmed. In this case, the range of the wavelength to be compared is the range shown on the Reference Spectrum.

The limit of contaminant in the sample can be confirmed by comparing the limit value specified in the monograph and the absorbance of the sample measured at the wavelength specific to impurities contaminated in the sample.

9. Residue on Ignition Test

Residue on Ignition Test is a method to measure the amount of residual substance not volatilized from a sample when the sample is ignited according to the procedure described below. This test is usually used for determining the content of inorganic impurities in an organic substance. In some cases, it is used for determining the content of inorganic substance contained as a component in an organic substance or the content of impurities contained in a volatile inorganic substance.

Sampling methods

Ignite a suitable crucible (for example, silica, platinum, quartz or porcelain) at $600\pm 50^{\circ}\text{C}$ for 30 minutes, cool the crucible in a desiccator (silica gel or suitable desiccant) and weigh it accurately.

Unless otherwise specified, weigh accurately 1 g of the sample, and perform the following procedure. When it is directed to perform the test "after drying the sample", weigh a sample dried under the conditions specified in the test for Loss on drying.

Procedure

Method 1

Moisten the sample with a small amount (usually 1 mL) of sulfuric acid, then heat gently at a temperature as low as practicable until the sample is thoroughly charred. After cooling, moisten the residue with a small amount (usually 1 mL) of sulfuric acid, heat gently until white fumes are no longer evolved, and ignite at $600\pm 50^{\circ}\text{C}$ until the residue is completely incinerated. Ensure that flames are not produced at any time during the procedure. Cool the crucible in a desiccator (silica gel or suitable desiccant), weigh accurately and calculate the percentage of residue.

Unless otherwise specified, if the amount of the residue so obtained exceeds the limit specified in the monograph, repeat the moistening with sulfuric acid, heating and ignition as before, using a 30-minute ignition period, until two consecutive weighings of the residue do not differ by more than 0.5 mg or until the percentage of residue complies with the limit in the monograph.

Method 2

Heat gradually the sample, and almost incinerate or volatilize at as low temperature as possible. Moisten it with sulfuric acid, incinerate completely, and ignite to constant mass. Cool in a desiccator (silica gel or suitable desiccant), and weigh the residue accurately.

Method 3

Heat the sample gently at first, and ignite gradually ($800\text{-}1200^{\circ}\text{C}$) until the residue is completely incinerated. Cool in a desiccator (silica gel or suitable desiccant), and weigh the residue accurately. If any carbonized substance remains, extract with hot water, filter through a sheet of filter paper for quantitative analysis (5C), and ignite the residue with the filter paper. Add the filtrate to it, evaporate to dryness, and ignite carefully until the carbonized substance does not remain. Cool in a desiccator (silica gel or suitable desiccant), and weigh the residue accurately. If any carbonized substance still remains under this method, add 15 mL of ethanol, crush the carbonized substance with a glass rod, burn the ethanol, ignite carefully and weigh accurately in the same manner.

10. Saponification Value Determination

Saponification Value Determination is a method to determine the amount of esters and free acids in the samples. The saponification value is the number of milligrams of potassium hydroxide (KOH: 56.11) required to saponify the esters and to neutralize the free acids in 1 g of the sample.

Procedure

Unless otherwise specified, weigh accurately 1 g of the sample, transfer to a 200-mL flask, and add exactly 25 mL of 0.5 mol/L potassium hydroxide-ethanol VS. Attach a short reflux condenser or an air condenser 750 mm in length and 6 mm in diameter to the neck of the flask, and heat gently on a water bath for 1 hour with occasional shaking. Cool the solution and titrate the excess potassium hydroxide with 0.5 mol/L hydrochloric acid VS (indicator: phenolphthalein TS). Perform a blank determination in the same manner.

$$\text{Saponification value} = \frac{(a-b) \times 28.053}{c}$$

- a: Volume (mL) of 0.5 mol/L hydrochloric acid VS consumed in the blank determination
- b: Volume (mL) of 0.5 mol/L hydrochloric acid VS consumed for titration of the sample
- c: Amount (g) of sample

11. Atomic Absorption Spectrophotometry

Atomic Absorption Spectrophotometry is a method to determine the amount or the concentration of an element in a sample specimen being examined, by utilizing the phenomenon that atoms being in the ground state absorb the light of specific wavelength, characteristic of the respective atom, when the light passes through an atomic vapor layer of the element to be determined.

Apparatus

Usually, the apparatus consists of a light source, a sample atomizer, a spectroscope, a photometer and a recording system. Some are equipped with a background compensation system. As a light source, usually a hollow cathode lamp specified for each element is used and sometimes a discharge lamp is also used. There are three types of sample atomizer: the flame type, the electrothermal type, and the cold-vapor type. The first one is composed of a burner and a gas-flow regulator, the second one is composed of an electric furnace and a power source, and the third one is composed of a mercury generator and an absorption cell. The third one is further classified into two subtypes, which differ in the atomizing method for mercury containing-compounds: one utilizes chemical reduction-vaporization and the other utilizes a thermal reduction-vaporization method. For the selection of an appropriate analytical wavelength in a spectroscope, a grating for light diffraction or an interference filter can be used. A recording system is composed of a display and a recording device. A background compensation system is employed for the correction of atmospheric effects on the measuring

system. Several principles can be utilized for background compensation, using continuous spectrum sources, the Zeeman splitted spectrum, the nonresonance spectrum, or self-inversion phenomena. Other special options such as a hydride generator and a heating cell, can also be used for analyzing such as selenium. As a hydride generator, a batch method and/or a continuous flow method can be applied. While as a heating cell, there are two kinds of cell: one for heating by flame and the other for heating by electric furnace.

Procedure

Unless otherwise specified, proceed by any of the following methods.

(1) Flame type

Fit the specific light source to the lamp housing and switch on the instrument. After lighting the lamp and selecting the analytical wavelength specified in the monograph, set an appropriate electric current and a slit-width. Next, a mixture of a combustible gas and a supporting gas is ignited and the gas flow rate and/or pressure should be adjusted to optimum conditions. The zero adjustment of the detecting system must be done through nebulizing the blank solvent into the flame. After setting up the measuring system, the sample solution prepared by the specified procedure is introduced into the flame and the light absorption at the characteristic wavelength of the element to be determined is measured.

(2) Electrothermal type

Fit the specific light source to the lamp housing and switch on the instrument. After lighting the lamp and selecting the analytical wavelength specified in the monograph, set an appropriate electric current and a slit-width. Further, set an electric furnace to the appropriate temperature, electric current, and heating program, as directed separately in the monograph. When a suitable amount of sample is injected into the heated furnace with an appropriate stream of inert gas, the sample is dried and ashed, simultaneously with atomization of the metallic compound included in the specimen. The atomic absorption specified is observed and the intensity of absorption is measured. Details of the sample preparation method are provided separately in the monograph.

(3) Cold vapor type

Fit the mercury lamp to the lamp housing and switch on the instrument. After lighting the lamp and selecting the analytical wavelength specified in the monograph, set an appropriate electric current and a slit-width. In the chemical atomization-vaporization method, a mercury containing compound in the sample solution, prepared by the specified procedure, is chemically reduced to metallic mercury by adding a proper reducing reagent to the closed vessel and the generated mercury is vaporized and introduced into the absorption cell with a flow of inert gas. In the thermal atomization-vaporization method, the sample specimen on a quartz dish is heated electrically and the generated atomic mercury is vaporized and introduced into the absorption cell with a flow of inert gas. Thus, in both methods, the generated atomic mercury is carried into the absorption cell as cold vapor and the intensity of the characteristic atomic absorption of mercury is measured.

12. Acid Value Determination

Acid Value Determination is a method to determine the number of milligrams of potassium hydroxide (KOH: 56.11) required to neutralize the free acids in 1 g of sample.

Procedure

Method 1

Unless otherwise specified, weigh accurately the amount of sample shown in the Table according to the expected acid value of the sample as well as the amount of solvent in the sample solution and place it in a glass-stoppered 250-mL flask. Add 100 mL (or 50 mL) of ethanol (95) or 100 mL (or 50 mL) of a mixture of diethyl ether and ethanol (95)(1:1 or 2:1) as the solvent, and dissolve the sample by warming if necessary. Then, add a few drops of phenolphthalein TS, and titrate with 0.1 mol/L potassium hydroxide-ethanol VS until the solution develops a light red color which persists for 30 seconds. Perform a blank determination in the same manner, and make any necessary correction.

$$\text{Acid value} = \frac{a \times 5.611}{b}$$

- a: Volume (mL) of 0.1 mol/L potassium hydroxide-ethanol VS consumed
b: Amount (g) of sample

Method 2

Unless otherwise specified, weigh accurately the amount of sample shown in the Table, according to the expected acid value of the sample as well as the amount of solvent in the sample solution and place it in a glass-stoppered 250-mL flask. Add 50 mL of ethanol (95) or 50 mL of a mixture of diethyl ether and ethanol (95)(1:1 or 1:2) as the solvent, and dissolve the sample by warming if necessary. Then, add a few drops of phenolphthalein TS, and titrate with 0.1 mol/L potassium hydroxide VS until the solution develops a light red color which persists for 30 seconds. Perform a blank determination in the same manner, and make any necessary correction.

$$\text{Acid value} = \frac{a \times 5.611}{b}$$

- a: Volume (mL) of 0.1 mol/L potassium hydroxide VS consumed
b: Amount (g) of sample

Table: Amount of sample

The amount of solvent: 100 mL		The amount of solvent: 50 mL	
Acid value	Amount (g) of sample	Acid value	Amount (g) of sample
less than 5	20	less than 5	10
not less than 5 and less than 15	10	not less than 5 and less than 15	5
not less than 15 and less than 30	5	not less than 15 and less than 50	3
not less than 30 and less than 100	2.5	not less than 50 and less than 120	1
not less than 100	1.0	not less than 120	0.5

13. Heavy Metals Limit Test

Heavy Metals Limit Test is a limit test of the quantity of heavy metals contained as impurities in a sample. The heavy metals are the metallic inclusions that are darkened with sodium sulfide TS in acidic solution, as their quantity is expressed in terms of the quantity of lead (Pb).

In the monograph, the permissible limit for heavy metals (as Pb) is described in terms of ppm.

Preparation of sample solutions and control solutions

Unless otherwise specified, sample solutions and control solutions are prepared as directed in the following.

Method 1

Place 1.0 g of the sample in a Nessler tube. Dissolve in water to make 40 mL. Add 2 mL of dilute acetic acid and water to make 50 mL, and designate it as the sample solution.

The control solution is prepared by placing the volume of Standard Lead Solution directed in the following Table (according to the limits specified in the monograph), in a Nessler tube and adding 2 mL of dilute acetic acid and water to make 50 mL.

Method 2

Place 1.0 g of the sample in a quartz or porcelain crucible, cover loosely with a lid, and carbonize by gentle ignition. After cooling, add 2 mL of nitric acid and 5 drops of sulfuric acid, heat gradually until the white fumes are no longer evolved, and incinerate by ignition between 500°C and 600°C. Cool, add 2 mL of hydrochloric acid, evaporate to dryness on a water bath, moisten the residue with 3 drops of hydrochloric acid, add 10 mL of hot water, and warm for 2 minutes. Add 1 drop of phenolphthalein TS, add ammonia TS dropwise until the solution develops a pale red color, add 2 mL of dilute acetic acid, filter if necessary, wash with 10 mL of water, transfer the filtrate and washings to a Nessler tube, and add water to make 50 mL. Designate it as the sample solution.

The control solution is prepared as follows: Evaporate a mixture of 2 mL of nitric acid, 5 drops of sulfuric acid, and 2 mL of hydrochloric acid on a water bath, further evaporate to dryness on a sand bath, and moisten the residue with 3 drops of hydrochloric acid. Hereinafter, proceed as directed in the sample solution, then add the volume of Standard Lead Solution directed in the following Table (according to the limits specified in the monograph) and water to make 50 mL.

Method 3

Place 1.0 g of the sample in a quartz or porcelain crucible, heat moderately at first and then incinerate by ignition between 450°C and 550°C. After cooling, add 2 mL of hydrochloric acid, evaporate to dryness on a water bath, add 2 mL of dilute acetic acid to the residue, filter if necessary, wash with 10 mL of water, transfer the filtrate and washings into a Nessler tube, add water to make 50 mL, and use this solution as the sample solution.

The control solution is prepared by placing the volume of Standard Lead Solution directed in the following Table (according to the limits specified in the monograph), in a Nessler tube and adding 2 mL of dilute acetic acid and water to make 50 mL.

Method 4

Place the sample solution prepared by the method directed in the monograph in a Nessler tube. Separately

place the volume of Standard Lead Solution directed in the monograph in a Nessler tube, add the solution treated in the same manner as the sample solution except for the sample, add further 2 mL of dilute hydrochloric acid and water to make 50 mL, and use this solution as the control solution.

Procedure

Add 1 drop of sodium sulfide TS to each of the sample solution and the control solution, mix thoroughly, and allow to stand for 5 minutes. Then compare the colors of both solutions by viewing the tubes downward or transversely against a white background. The sample solution has no more color than the control solution.

Table: Volume of Standard Lead Solution to be taken in the heavy metals limit test
(amount of the sample, 1.0 g)

Limit	Volume of Standard Lead Solution	Limit	Volume of Standard Lead Solution
10 ppm	1 mL	30 ppm	3 mL
20 ppm	2 mL	50 ppm	5 mL

14. Infrared Spectrophotometry

Infrared Spectrophotometry is a method of measurement of the extent, at various wave numbers, of absorption of infrared radiation when it passes through a layer of a substance. In the graphic representation of infrared spectra, the plot usually shows units of wave numbers as the abscissa and units of transmittance or absorbance as the ordinate. Wave number and transmittance or absorbance at each absorption maximum may be read graphically on an absorption spectrum and/or obtained by a data-processor. Since the wave number and the respective intensity of an absorption maximum depend on the chemical structure of a substance, this measurement can be used to identify or determine a substance.

Apparatus and adjustment

Several models of dispersive infrared spectrophotometers or Fourier-transform infrared spectrophotometers are available.

The instruments, adjusted according to the instruction manual of each individual instrument, should comply with the following test for resolving power, transmittance reproducibility and wave number reproducibility. When the spectrum of a polystyrene film about 0.04 mm thick is recorded, the depth of the trough from the maximum absorption at about 2850 cm⁻¹ to the minimum at about 2870 cm⁻¹ should be not less than 18% transmittance and that from the maximum at about 1583 cm⁻¹ to the minimum at about 1589 cm⁻¹ should be not less than 12% transmittance.

The wave number (cm⁻¹) scale is usually calibrated by the use of several characteristic absorption wave numbers (cm⁻¹) of a polystyrene film shown below. The number in parentheses indicates the permissible range.

3060.0(±1.5)	2849.5(±1.5)	1942.9(±1.5)	1601.2(±1.0)
1583.0(±1.0)	1154.5(±1.0)	1028.3(±1.0)	

When the dispersive infrared spectrophotometer is used, the permissible range of the absorption wave numbers at 1601.2 cm^{-1} and at 1028.3 cm^{-1} should be both within $\pm 2.0\text{ cm}^{-1}$.

As the repeatability of transmittance and wave number, the difference of transmittance should be within 0.5% when the spectrum of a polystyrene film is measured twice at several wave numbers from 3000 to 1000 cm^{-1} , and the difference of wave number should be within 5 cm^{-1} at about 3000 cm^{-1} and within 1 cm^{-1} at about 1000 cm^{-1} .

Preparation of samples and measurement

Unless otherwise specified, when it is directed to perform the test “after drying the sample”, use a sample dried under the conditions of “loss on drying” specified in the monograph. Prepare the specimen for the measurement according to one of the following procedures so that the transmittance of most of the absorption bands is in the range of 5% to 80%. Single crystals of sodium chloride, potassium bromide, etc. are available for the optical plate. Generally, the reference cell or material is placed in the reference beam for double-beam instruments, while for single-beam instruments, it is placed in the same optical path in place of the specimen and measured separately under the same operating conditions. The composition and preparation of the reference depend on the sample preparation methods, and sometimes the background absorption of the atmosphere can be utilized.

Unless otherwise specified in the monograph, the spectrum is usually recorded between 4000 cm^{-1} and 400 cm^{-1} . The spectrum should be scanned using the same instrumental conditions as were used to ensure compliance with the requirements for the resolving power and for the precision of wave number scale and of wave numbers.

In specifying absorption wave numbers, wave numbers are rounded off to the nearest 10 cm^{-1} and add “about” before them if they are not less than 2000 cm^{-1} .

(1) Potassium bromide disk method

Powder 1 to 2 mg of a solid sample in an agate mortar, triturate rapidly with 0.10 to 0.20 g of potassium bromide for infrared spectrophotometry with precautions against moisture absorption, and compress the mixture with a press in a suitable die (disk-forming container) to make the sample disk. If necessary to obtain a transparent disk, press the mixture under vacuum of not more than 0.67 kPa in a die with pressure applied to the die of 50 to 100 kN (5000 to 10000 kg) per cm^2 for 5 to 8 minutes. Prepare a potassium bromide reference disk or a potassium chloride reference disk in the same manner as the sample disk.

(2) Solution method

Place the sample solution prepared by the method directed in the monograph in a fixed cell for liquid, and usually measure the spectrum against the reference solvent used for preparing the sample solution. The solvent used in this method should not show any interaction or chemical reaction with the specimen to be examined and should not damage the optical plate. The thickness of the fixed cell is usually 0.1 mm or 0.5 mm.

(3) Film method

Examine the thin film sample just as it is. When the sample is powder, particle, or fiber, etc., unless otherwise specified, prepare the sample film as directed in the following.

- 1) Heat, melt, and compress the sample to prepare the sample film.

- 2) Dissolve the sample in an appropriate solvent, apply to the window plate, and evaporate the solvent to prepare the sample film.

Identification

When several specific absorption wave numbers of the substance being examined are specified in the monograph, a specimen can be identified as being the same substance as the expected substance by confirmation of clear appearance of the absorption bands at all the specified wave numbers.

15. Qualitative Tests

Qualitative Tests are applied to the identification of materials and are done generally with quantities of 2 to 5 mL of the sample solution directed in the monograph.

Aluminum salt

Solutions of aluminum salts, when treated with sodium hydroxide TS, yield a gelatinous, white precipitate which dissolves in an excess of the reagent.

Potassium salt

When the Flame Coloration Test is applied to potassium salts, a pale purple color develops. When it gives a yellow color, a red-purple color can be seen through cobalt glass.

Calcium salt

- (1) When 4. Flame Coloration Test is applied to calcium salts, a yellow-red color develops.
- (2) Solutions of calcium salts yield a white precipitate with ammonium carbonate TS.
- (3) Solutions of calcium salts yield a white precipitate with ammonium oxalate TS. The separated precipitate does not dissolve in dilute acetic acid, but dissolves with additional dilute hydrochloric acid.
- (4) Neutral solutions of calcium salts produce no precipitate, when mixed with 10 drops of potassium chromate TS and heated (discrimination from strontium salts).

Sodium salt

When the Flame Coloration Test is applied to sodium salts, a yellow color develops.

Sulfate

- (1) Solutions of sulfates yield with barium chloride TS a white precipitate, which does not dissolve upon addition of dilute nitric acid.
- (2) When an equal volume of dilute hydrochloric acid is added, solutions of sulfates yield no white turbidity (discrimination from thiosulfates), and do not evolve the odor of sulfur dioxide (discrimination from sulfites).

16. Viscosity Determination

Viscosity Determination is a method to determine the viscosity of liquid samples using a viscometer.

When a liquid moves in a definite direction, and the liquid velocity has a gradient with respect to the direction

rectangular to that of flow, a force of internal friction is generated along both sides of a hypothetical plane parallel to the movement. This flow property of a liquid is expressed in terms of viscosity. The internal friction per unit area on the parallel plane is called slip stress or shear stress, and the velocity gradient with respect to the direction rectangular to that of flow is called slip velocity or shear velocity. A liquid of which the slip velocity is proportional to its slip stress is called a Newtonian liquid. The proportionality constant, η , is a characteristic of a liquid at a certain temperature and is called viscosity. The viscosity is expressed in the unit of Pascal second (Pa·s), and usually milli-Pascal second (mPa·s).

A liquid whose slip velocity is not proportional to its slip stress is called a non-Newtonian liquid. Since the viscosity for a sample of a non-Newtonian liquid changes with its slip velocity, the viscosity measured at a certain slip velocity is called an apparent viscosity. In that case, the value of slip stress divided by the corresponding slip velocity is called an apparent viscosity. Thus, the relationship between apparent viscosity and slip velocity will permit characterization of the flow properties of a given non-Newtonian liquid.

The value of the viscosity, η , divided by the density, ρ , at the same temperature is defined as a kinematic viscosity, ν , which is expressed in the unit of square meter per second (m^2/s), and usually square millimeter per second (mm^2/s).

The viscosity of a liquid is determined either by the following Method 1 or Method 2.

Method 1: Viscosity measurement by capillary tube viscometer

For measuring the viscosity of a Newtonian liquid, a capillary tube viscometer is usually used, in which the downflowing time of a liquid, t (s), required for a definite volume of the liquid to flow through a capillary tube is measured and the kinematic viscosity, ν , is calculated according to the following equation.

$$\nu = Kt$$

Further, the viscosity, η , is calculated from the next equation: where ρ (g/mL) is the density of the sample measured at the same temperature, t ($^{\circ}\text{C}$).

$$\eta = \nu\rho = Kt\rho$$

The parameter K (mm^2/s^2) represents the viscometer constant and is previously determined by using the Standard Liquids for Calibrating Viscometers with known kinematic viscosity. In the case of a liquid having a similar viscosity to water, water itself can be used as a reference standard liquid for the calibration. The kinematic viscosity of water is $1.0038 \text{ mm}^2/\text{s}$ at 20°C . In the cases of liquids having a slightly higher viscosity than water, the Standard Liquids for Calibrating Viscometers should be used for the calibration.

The intrinsic viscosity, $[\eta]$ (dL/g), of a polymer solution is obtained by plotting the relation of viscosity versus concentration and extrapolating the obtained straight line to zero concentration. Intrinsic viscosity shows the degree of molecular expansion of a polymer substance in a given solvent (sample solution) and is also a measure of the average molecular mass of the polymer substance. The downflowing time t (s) for a polymer solution, whose concentration is c (g/dL), and t_0 (s) for the solvent used for dissolving the polymer, are measured by using the same viscometer, and then the intrinsic viscosity of a given polymer substance, $[\eta]$, is calculated according to the following equation:

$$[\eta] = \lim_{c \rightarrow 0} \frac{(t/t_0) - 1}{c} \quad \text{Or} \quad [\eta] = \lim_{c \rightarrow 0} \frac{\ln(t/t_0)}{c}$$

When the concentration dependency of $\{(t/t_0)-1\}/c$ is not large, the value of $\{(t/t_0)-1\}/c$ at a concentration directed in the respective monograph can be assumed to be the intrinsic viscosity for a given substance. The downflowing time of a sample solution is measured with the following apparatus and procedure.

Apparatus

For measurement of the kinematic viscosity in the range of 1 to 100,000 mm²/s, the Ubbelohde-type viscometer illustrated in Fig. 1 can be used. The approximate relations between kinematic viscosity range and inside diameter of the capillary tube suitable for the measurement of various liquids with different viscosity, are given in Table 1. Although a capillary tube viscometer other than the Ubbelohde-type one specified in Table 1 can also be used, a viscometer should be selected in which the downflowing time, t (s), of a sample solution to be determined would be between 200 s and 1000 s.

Procedure

Transfer a sample solution gently into a viscometer from the upper end of Tube 1, so that the meniscus of the solution is at a level between the two marked lines of Bulb A when the viscometer is placed vertically. Place the viscometer vertically in a thermostatted bath maintained at the specified temperature within $\pm 0.1^\circ\text{C}$, until Bulb C is fully immersed, and let it stand for about 20 minutes to attain the specified temperature. Close tube 3 with a finger and pull the sample solution up to the middle part of Bulb C by gentle suction from the top of Tube 2, taking care not to introduce any bubbles into Tube 2, and stop the suction. Open the end of Tube 3, and immediately close the end of Tube 2. After confirming that the liquid column is cut off at the lowest end of the capillary tube, open the end of Tube 2 to make the sample solution flow down through the capillary tube. Record the time, t (s), required for the meniscus of the sample solution to fall from the upper to the lower marked line of Bulb B.

Determine the viscometer constant K previously, using the Standard Liquids for Calibrating Viscometers under the same conditions. The temperature at which the calibration is conducted must be identical with that specified in the monograph.

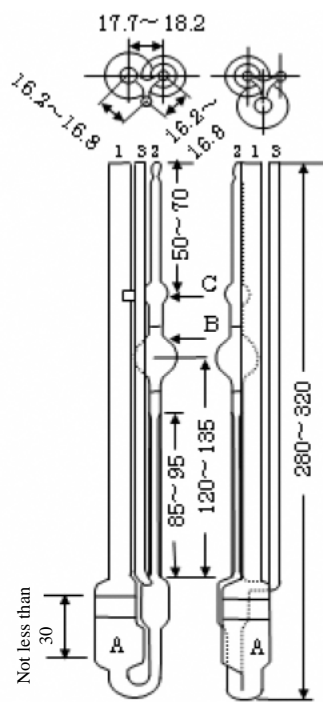

(The figures are in mm.)

Fig. 1 Capillary tube viscometer

Table 1: Specifications of the Ubbelohde-type viscometer

Viscometer constant (K)(mm ² /s ²)	Inner diameter of capillary tube (mm) Permissible tolerance ± 10%	Volume of Bulb B (mL) Permissible tolerance ± 10%	Measuring range of kinematic viscosity (mm ² /s)
0.005	0.46	3.0	1-5
0.01	0.58	4.0	2-10
0.03	0.73	4.0	6-30
0.05	0.88	4.0	10-50
0.1	1.03	4.0	20-100
0.3	1.36	4.0	60-300
0.5	1.55	4.0	100-500
1.0	1.83	4.0	200-1000
3.0	2.43	4.0	600-3000
5.0	2.75	4.0	1000-5000
10.0	3.27	4.0	2000-10000
30.0	4.32	4.0	6000-30000
50.0	5.20	5.0	10000-50000
100.0	6.25	5.0	20000-100000

Method 2: Viscosity measurement by rotational viscometer

A rotational viscometer is usually used for measuring the viscosity of Newtonian or non-Newtonian liquids.

The measuring principle of a rotational viscometer generally consists in the detection and determination of the force acting on a rotor (torque), when it rotates at a constant angular velocity in a liquid. The extent of torque generated by the rotation can be detected in terms of the torsion of a spring and the liquid viscosity is calculated from the scale-indicated value corresponding to the degree of torsion.

The viscosity of a sample solution is measured with the following apparatus and procedure.

Apparatus

Viscosity measurement is performed by using any one of the following three types of rotational viscometers.

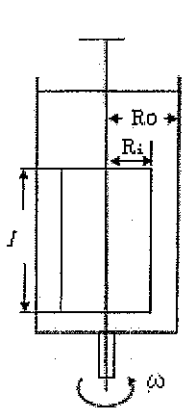

Fig. 2 Coaxial double cylinder-type rotational viscometer

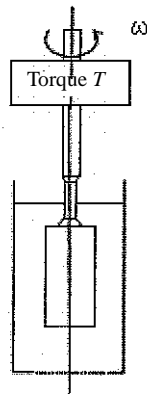

Fig. 3 Single cylinder-type rotational viscometer

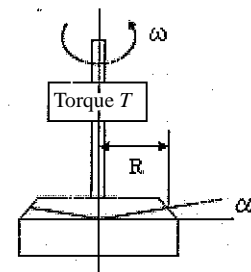

Fig. 4 Cone-flat plate-type rotational viscometer

(1) Coaxial double cylinder-type rotational viscometer (Couette type viscometer)

In the coaxial double cylinder-type rotational viscometer, viscosity is determined by placing a liquid in the gap between the inner and the outer cylinders, which share the same central axis and rotate separately, and the generated torque acting on one cylinder surface when the other cylinder is rotated, and the corresponding angular velocity, are measured.

As shown in Fig. 2, the inner cylinder is hung by a wire whose twist constant is designated as k . In Fig. 2, half the outer diameter of the inner cylinder and inner diameter of the outer cylinder are designated as R_i and R_o , respectively, and the length of the inner cylinder immersed in a liquid is designated as l . When a liquid is introduced into the gap between the two cylinders, and the outer cylinder is made to rotate at a constant angular velocity, ω , the inner cylinder is also forced to rotate due to the viscosity of the liquid. Consequently, torque, T , is generated by the forced rotation in a viscous liquid, and in the steady state the torque is balanced by the torsion of the wire, as indicated by the degree of rotation θ . Then, the relationship can be expressed by $T = k\theta$ and the viscosity of a liquid, η , is determined from the following equation by measuring the relationship between ω and θ . Conversely, viscosity measurement can also be performed by rotating the inner cylinder, and the same relationship holds.

$$\eta = \frac{100T}{4\pi l\omega} \left(\frac{1}{R_i^2} - \frac{1}{R_o^2} \right)$$

η : Viscosity of a liquid (mPa·s)

π : Circumference/diameter ratio

l : Length of the inner cylinder (cm)

ω : Angular velocity (rad/s)

T : Torque acting on cylinder surface (10^{-7} N·m)

R_i : 1/2 of outer diameter of the inner cylinder (cm)

R_o : 1/2 of inner diameter of the outer cylinder (cm)

(2) Single cylinder-type rotational viscometer (Brookfield type viscometer)

In the single cylinder-type rotational viscometer, viscosity is determined by measuring the torque acting on the cylinder surface when the cylinder immersed in a liquid is rotated at a given angular velocity. Use an apparatus of the type illustrated in Fig. 3-5. If the apparatus constant K_B is previously determined experimentally by using the Standard Liquids for Calibrating Viscometers, the viscosity of a liquid, η , can be obtained from the following equation.

$$\eta = K_B \frac{T}{\omega}$$

η : Viscosity of a liquid (mPa·s)

K_B : Apparatus constant of viscometer (rad/cm³)

ω : Angular velocity (rad/s)

T : Torque acting on cylinder surface (10^{-7} N·m)

(3) Cone-flat plate-type rotational viscometer (Coneplate type viscometer)

In the cone-flat plate-type rotational viscometer, viscosity is determined by placing a liquid in the gap between a flat disc and a cone with a large vertical angle sharing the same rotational axis, and the torque and the corresponding angular velocity are measured, when either the disc or the cone is rotated in a viscous liquid. As shown in Fig. 4, a liquid is introduced to fill the gap between a flat disc and a cone forming an angle α (rad). When either the flat disc or the cone is rotated at a constant angular velocity or a constant torque, the torque acting on the disc or cone surface rotated by the viscous flow and the corresponding angular velocity in the steady state, are measured. The viscosity of the liquid, η , can be calculated from the following equation.

$$\eta = \frac{3\alpha}{2\pi R^3} \cdot \frac{100T}{\omega}$$

η : Viscosity of a liquid (mPa·s)

π : Circumference/diameter ratio

R : Radius of cone (cm)

α : Angle between flat disc and cone (rad)

ω : Angular velocity (rad/s)

T : Torque acting on flat disc or cone surface (10^{-7} N·m)

Procedure

(1) Rotational viscometer

Set up the viscometer so that its rotational axis is perpendicular to the horizontal plane. Prepare the sample solution as directed in the monograph, place a sufficient quantity of a sample solution in the viscometer, and allow the measuring system to stand until a specified temperature is attained, as directed in the monograph.

Where it is desired to measure the viscosity within a precision of 1%, measuring temperature should be controlled within $\pm 0.1^\circ\text{C}$. Next, after confirming that the sample solution is at the designated temperature, start operating the rotational viscometer. After the forced rotation induced by the viscous flow has reached a steady state and the indicated value on the scale, which corresponds to the rotational frequency or the torque, has become constant, read the value on the scale. Then, calculate the viscosity η by using the respective equation appropriate to the type of viscometer being used. Determination or confirmation of the apparatus constant should be conducted beforehand by using the Standard Liquids for Calibrating Viscometers, and the validation of the apparatus and operating procedure should also be performed by using those standard liquids.

In the case of a non-Newtonian liquid, repeat the procedure for measuring the apparent viscosity of the liquid with variation of the rotation velocity or torque from one measurement to another. From a series of such viscosity measurements, the relationship between the slip velocity and the slip stress of a non-Newtonian liquid, i.e., the flow characteristics of a non-Newtonian liquid, can be obtained.

Calibration of a rotational viscometer is conducted by using water and the Standard Liquids for Calibrating Viscometers. These standard liquids are used for the determination or confirmation of the apparatus constant of the rotational viscometer. They are also used for periodic recalibration of the viscometer to confirm maintenance of a specified precision.

(2) Brookfield type viscometer

Use the rotor in various types and changeable rotation frequency which are suitable for the sample solution.

Prepare Rotor E and Guard F specified in the monograph. Fix the rotation frequency specified in the monograph by Change knob of rotation frequency A. Immerse gently Rotor E into the container filled with the sample solution, so that the surface of the sample solution is on a level with Mark of immersion point D.

Switch on, and rotate Rotor E: Indicator B moves from zero on Scale plate C. After Indicator B becomes stable after a lapse of sufficient time, stop the rotor. Measure the value by Indicator B on Scale plate C. Multiply the measuring value by the calculation constant specified in Table 2 by the type of rotor E and its rotation frequency. The resultant value indicates the absolute viscosity (mPa·s) of the sample.

For example, 1500 to 2500 mPa·s (No. 2, 12 rotations, 30 seconds), directed in the monograph, mean that the viscosity of the sample is 1500 to 2500 mPa·s, when No. 2 rotor is rotated for 30 seconds at the frequency of 12 rotations per minute. Otherwise, 30000 to 40000 mPa·s (No. 4, 12 rotations, constant), directed in the monograph, mean that the viscosity of the sample is 30000 to 40000 mPa·s, when No. 4, rotor is rotated at the frequency of 12 rotations per minute until the indicator on the scale plate becomes constant.

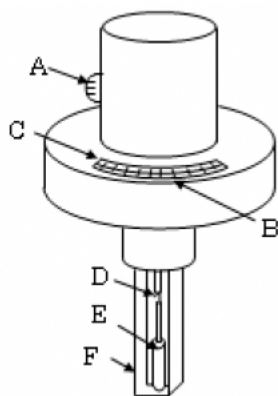

Fig. 5 Rotational viscometer

A: Change knob of rotation frequency, B: Indicator, C: Scale plate, D: Mark of immersion point, E: Rotor, F: Guard

Table 2 Calculation constant

Rotation frequency \ Type of rotor	60	30	12	6
Adaptor	0.1	0.2	0.5	1.0
No.1	1	2	5	10
No.2	5	10	25	50
No.3	20	40	100	200
No.4	100	200	500	1000

17. pH Determination

pH is defined as the reciprocal of the common logarithm of hydrogen ion activity, which is the product of hydrogen ion concentration and the activity coefficient. Conventionally, it is used as a scale of hydrogen ion concentration of a sample solution.

pH of a sample solution is expressed by the following equation in relation to the pH of a standard solution (pH_s), and can be measured by a pH meter using a glass electrode.

$$pH = pH_s + \frac{E - E_s}{2.3026RT / F}$$

pH_s : pH value of a pH standard solution

E : Electromotive force (volt) induced on the following galvanic cell composed of a glass electrode and suitable reference electrode in a sample solution.

Glass electrode | Sample solution | Reference electrode

E_s : Electromotive force (volt) induced on the following galvanic cell composed of a glass electrode and suitable reference electrode in a pH standard solution.

Glass electrode | pH standard solution | Reference electrode

R : Gas constant

T : Absolute temperature

F : Faraday's constant

The value of $2.3026 RT/F$ (V) in the above equation means the degree of electromotive force (V) per one pH unit and it is dependent on the temperature as shown in Table 1.

Table 1: Temperature dependency of the electromotive force (V)

Temperature of solution (°C)	2.3026 RT/F (V)	Temperature of solution (°C)	2.3026 RT/F (V)
5	0.05519	35	0.06114
10	0.05618	40	0.06213
15	0.05717	45	0.06313
20	0.05817	50	0.06412
25	0.05916	55	0.06511
30	0.06015	60	0.06610

pH standard solution

The pH standard solutions are used as a standard of pH, for standardization of a pH meter. To prepare water for preparation of the pH standard solutions, distill purified water, boil the distillate for more than 15 minutes, and cool in a container fitted with a carbon dioxide-absorbing tube (soda lime). Next, prepare individually 6 kinds of pH standard solutions shown in Table 2 by the procedure specified in the following.

Store hermetically the pH standard solutions in hard glass or polyethylene bottles. For storage of alkaline pH standard solutions, it is preferable to use a bottle fitted with a carbon dioxide-absorbing tube. Since the pH

may change gradually during storage over a long period, it is necessary to ascertain whether the expected pH value is held or not by comparison with newly prepared standard, when the solution is used after long storage.

- (1) Oxalate pH Standard Solution: Pulverize potassium trihydrogen dioxalate dihydrate for pH determination, and dry in a desiccator (silica gel). Weigh 12.71 g (0.05 mol) of it accurately, and dissolve in water to make exactly 1000 mL.
- (2) Phthalate pH Standard Solution: Pulverize potassium hydrogen phthalate for pH determination, and dry at 110°C to constant mass. Weigh 10.21 g (0.05 mol) of it accurately, and dissolve in water to make exactly 1000 mL.
- (3) Phosphate pH Standard Solution: Pulverize potassium dihydrogen phosphate for pH determination and disodium hydrogen phosphate for pH determination, and dry at 110°C to constant mass. Weigh 3.40 g (0.025 mol) of potassium dihydrogen phosphate and 3.55 g (0.025 mol) of disodium hydrogen phosphate accurately, and dissolve in water to make exactly 1000 mL.
- (4) Borate pH Standard Solution: Allow sodium tetraborate decahydrate for pH determination to stand in a desiccator (saturated sodium bromide aqueous solution) until it reaches constant mass. Weigh 3.81 g (0.01 mol) of it accurately, and dissolve in water to make exactly 1000 mL.
- (5) Carbonate pH Standard Solution: Dry sodium hydrogen carbonate for pH determination in a desiccator (silica gel) to constant mass, and weigh 2.10 g (0.025 mol) of it accurately. Dry sodium carbonate for pH determination between 300°C and 500°C to constant mass, and weigh 2.65 g (0.025 mol) of it accurately. Dissolve both reagents in water to make exactly 1000 mL.
- (6) Calcium Hydroxide pH Standard Solution: Reduce calcium hydroxide for pH determination to a fine powder, transfer 5 g to a flask, add 1000 mL of water, shake well, and allow the solution to become saturated at a temperature between 23°C and 27°C. Then filter the supernatant at the same temperature and use the clear filtrate (about 0.02 mol/L).

The pH values of these pH standard solutions at various temperatures are shown in the Table 2. pH values at an arbitrary temperature not indicated in Table 2 can be calculated by the interpolation method.

Table 2: Temperature dependency of pH in 6 pH standard solutions

Temperature (°C)	Oxalate pH Standard Solution	Phthalate pH Standard Solution	Phosphate pH Standard Solution	Borate pH Standard Solution	Carbonate pH Standard Solution	Calcium Hydroxide pH Standard Solution
0	1.67	4.01	6.98	9.46	10.32	13.43
5	1.67	4.01	6.95	9.39	10.25	13.21
10	1.67	4.00	6.92	9.33	10.18	13.00
15	1.67	4.00	6.90	9.27	10.12	12.81
20	1.68	4.00	6.88	9.22	10.07	12.63
25	1.68	4.01	6.86	9.18	10.02	12.45
30	1.69	4.01	6.85	9.14	9.97	12.30
35	1.69	4.02	6.84	9.10	9.93	12.14
40	1.70	4.03	6.84	9.07		11.99

50	1.71	4.06	6.83	9.01		11.70
60	1.73	4.10	6.84	8.96		11.45

Apparatus

A pH meter generally consists of an electrode system of a glass electrode and a reference electrode, an amplifier and an indicating unit for controlling the apparatus and for displaying the measured value of electromotive force. The indicating unit is usually fitted with dials for zero and span (sensitivity) adjustment. Sometimes a temperature compensation dial is included.

The reproducibility of a pH meter should be within ± 0.05 pH unit, when measurements for an arbitrary pH standard solution are repeated five times, following the procedure described below. After each measurement it is necessary to wash the detecting unit well with water.

Procedure

Immerse the glass electrode previously in water for more than several hours. Start the measurement after confirming stable running of the apparatus. Rinse well the detecting unit with water, and remove the remaining water gently with a piece of filter paper.

To standardize the pH meter, two pH standard solutions are usually used as follows. Immerse the detection unit in the phosphate pH standard solution and adjust the indicated pH to the pH value shown in the Table by using a zero-adjusting dial. Next, immerse the detection system in the second pH standard solution, which should be selected so that the expected pH of the sample solution to be determined is between the pH values of the two pH standard solutions, and measure the pH under the same conditions as used for the first pH standard solution. Adjust the indicated pH to the defined pH value using the span adjustment dial, when the observed pH is not identical with that tabulated. Repeat the above standardization procedure until both pH standard solutions give observed pH values within ± 0.05 pH unit of the tabulated value without further adjustments. When a pH meter is fitted with a temperature compensation dial, the standardization procedure is done after the setting of the temperature to that of the pH standard solution to be measured.

In the case of using an apparatus having an auto-calibration function, it is necessary to confirm periodically that the pH values of two pH standard solutions are identical with the tabulated values within ± 0.05 pH unit. After finishing the standardization procedure described above, rinse well the electrodes with water, remove the attached water using a filter paper, immerse the electrode system in the sample solution, and read the indicated pH value after confirming the value is stable. If necessary, a sample solution can be agitated gently.

In the pH determination, the temperature of a sample solution must be controlled to be the same as that of the pH standard solutions with which the pH meter was standardized (within 2°C). When a sample solution is alkaline, the measurement should be done in a vessel with a cover and if necessary, in a stream of inert gas such as nitrogen. Furthermore for a strongly alkaline solution above pH 11 containing alkali metal ions, an alkali error may be induced in the pH measurement. Thus, in such a case, an electrode with less alkali error should be used and an appropriate correction should be applied to the measured value.

Note: Construction and treatment in detail are different for different pH meters.

18. Determination of Specific Gravity and Density

The density ρ (g/mL or g/cm³) means the mass per unit volume, and the relative density means the ratio of the mass of a sample specimen to that of an equal volume of a standard substance. The relative density is also called the specific gravity.

The specific gravity $d_t^{t'}$ means the ratio of the mass of the sample specimen at $t'^{\circ}\text{C}$ to that of an equal volume of water (H₂O) at $t^{\circ}\text{C}$. Unless otherwise specified, the specific gravity is the value of d_t^{20} .

Method 1: Measurement using a pycnometer

(1) Liquid samples

A pycnometer is a glass vessel with a capacity of usually 10 mL to 100 mL, having a ground-glass stopper fitted with a thermometer, and a side inlet-tube with a marked line and a ground-glass cap. Weigh a pycnometer, previously cleaned and dried, to determine its mass W . Remove the stopper and the cap. Fill the pycnometer with the sample solution, keeping them at a slightly lower temperature by 1°C to 3°C than the specified temperature $t'^{\circ}\text{C}$, and stopper them, taking care not to leave bubbles. Raise the temperature gradually, and when the thermometer shows the specified temperature, remove the portion of the sample solution above the marked line through the side tube, cap the side tube, and wipe the outside surface thoroughly. Measure the mass W_1 of the pycnometer filled with the sample solution. Perform the same procedure, using the same pycnometer containing water, and note the mass W_w at the specified temperature $t^{\circ}\text{C}$. The specific gravity $d_t^{t'}$ can be calculated by use of the following equation.

$$d_t^{t'} = \frac{W_1 - W}{W_w - W}$$

Further, when measurements for a sample solution and water are performed at the same temperature ($t'^{\circ}\text{C} = t^{\circ}\text{C}$), the density of the sample solution at the temperature $t'^{\circ}\text{C}$ ($\rho_T^{t'}$) can be calculated from the measured specific gravity $d_t^{t'}$ and the density of water at the temperature $t^{\circ}\text{C}$ (ρ_W^t) indicated in Table 1 by using the following equation.

$$\rho_T^{t'} = \rho_W^t d_t^{t'}$$

Table 1 Density of water (ρ_W^t)

Temperature °C	Density g/mL	Temperature °C	Density g/mL	Temperature °C	Density g/mL	Temperature °C	Density g/mL
0	0.99984	10	0.99970	20	0.99820	30	0.99565
1	0.99990	11	0.99961	21	0.99799	31	0.99534
2	0.99994	12	0.99950	22	0.99777	32	0.99503
3	0.99996	13	0.99938	23	0.99754	33	0.99470
4	0.99997	14	0.99924	24	0.99730	34	0.99437
5	0.99996	15	0.99910	25	0.99704	35	0.99403
6	0.99994	16	0.99894	26	0.99678	36	0.99368
7	0.99990	17	0.99877	27	0.99651	37	0.99333
8	0.99985	18	0.99860	28	0.99623	38	0.99297

9	0.99978	19	0.99841	29	0.99594	39	0.99259
10	0.99970	20	0.99820	30	0.99565	40	0.99222

(2) Solid samples

A pycnometer which is suitable for solid samples is used. Use the sample pulverized appropriately. If the sample is in the form of powders, granules, pellets or flakes of measurable size, use the sample as it is. Weigh a pycnometer, previously cleaned and dried, to determine its mass W down to the degree of 1.0 mg. Place an adequate amount of sample in the pycnometer and measure its mass W_1 . Add the immersion liquid, keeping the temperature of the liquid 1 to 3°C lower than the specified temperature t' °C, to immerse the sample. Place the pycnometer in a desiccator and hold it with vacuum to remove air completely. Return the pressure to ordinal, fill the pycnometer with the immersion liquid, place the pycnometer in a water bath and keep it at the specified temperature t' °C. Next, exactly fill the pycnometer to its capacity with the immersion liquid, wipe out the attached liquid thoroughly and measure its mass W_2 . Empty the pycnometer, clean, wipe it. Then, fill the pycnometer with boiled and cooled distilled water, deaerate it in the same manner as described above, and measure the mass W_w at the specified temperature t' °C. When water is used as the immersion liquid, the specific gravity $d_t^{t'}$ ($t' = t$) can be calculated by the following equation.

$$d_t^{t'} = \frac{W_1 - W}{(W_w - W) - (W_2 - W_1)}$$

When the immersion liquid other than water is used, follow the same procedure using the given immersion liquid, measure the mass W_{IL} and calculate the density ($\rho_{IL}^{t'}$) of that immersion liquid by using the following equation.

$$\rho_{IL}^{t'} = \frac{W_{IL} - W}{W_w - W} \times \rho_w^t$$

ρ_w^t : Density (g/cm³) of water at the specified temperature t (see Table 1)

The density of the sample ($\rho_T^{t'}$) can be calculated by the equation.

$$\rho_T^{t'} = \frac{(W_1 - W) \times \rho_{IL}^{t'}}{(W_{IL} - W) - (W_2 - W_1)}$$

When t' is not equal to t , the specific gravity $d_t^{t'}$ of the sample can be calculated by using the density of water at t (ρ_w^t , Table 1) by the following equation.

$$d_t^{t'} = \frac{\rho_T^{t'}}{\rho_w^t}$$

Immersion liquid

The immersion liquid is the liquid with known density which does not dissolve, swell or react with the sample and whose specific gravity is lower than that of the sample. Usually, new distilled water, purified mineral oil, etc. are used. No more than 0.1% of an appropriate moistening agent may be added to the immersion liquid to expel any entrapped air bubbles.

Method 2: Measurement using a Sprengel-Ostwald pycnometer

A Sprengel-Ostwald pycnometer is a glass vessel with a capacity of usually 1 mL to 10 mL. As shown in Fig. 1, both ends are thick-walled fine tubes (inside diameter: 1-1.5 mm, outside diameter: 3-4 mm), one of which, tube A, has a line marked C on it. Determine the mass of a pycnometer, W , previously cleaned and dried, by hanging it on the arm of a chemical balance with a platinum or aluminum wire D. Immerse the fine tube B in the sample solution, which is at a lower temperature by 3°C to 5°C than the specified temperature $t^\circ\text{C}$. Attach rubber tubing or a ground-glass tube to the end of A, and suck up the sample solution until the meniscus is above the marked line C, taking care to prevent bubble formation. Immerse the pycnometer in a water bath kept at the specified temperature $t^\circ\text{C}$ for about 15 minutes, and then, by attaching a piece of filter paper to the end of B, adjust the level of the sample solution to the marked line C. Take the pycnometer out of the water bath, wipe thoroughly the outside surface and determine the mass W_1 . By use of the same pycnometer, perform the same procedure for the standard solution of water. Weigh the pycnometer containing water at the specified temperature $t^\circ\text{C}$, and note the mass W_w . Calculate the specific gravity $d_t^{t'}$ according to the following equation.

$$d_t^{t'} = \frac{W_1 - W}{W_w - W}$$

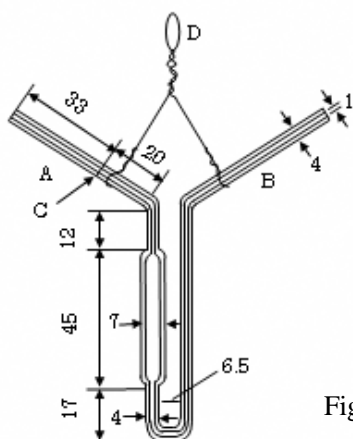

(The figures are in mm.)

Fig. 1 Measurement using a Sprengel-Ostwald pycnometer

Further, when measurements for a sample solution and water are performed at the same temperature ($t^\circ\text{C} = t^\circ\text{C}$), the density of the sample solution at the temperature $t^\circ\text{C}$ ($\rho_T^{t'}$) can be calculated from the measured specific gravity $d_t^{t'}$ and the density of water at the temperature $t^\circ\text{C}$ (ρ_W^t) indicated in Table 1 by using the following equation.

$$\rho_T^{t'} = \rho_W^t d_t^{t'}$$

Method 3: Measurement using an oscillator-type density meter

Density measurement with an oscillator-type density meter is a method for obtaining the density of liquid or gas by measuring the intrinsic vibration period T (s) of a glass tube cell filled with sample specimen. When a glass tube containing a sample is vibrated, it undergoes a vibration with an intrinsic vibration period T in proportion to the mass of the sample specimen. If the volume of the vibrating part of the sample cell is fixed, the relation of the square of intrinsic oscillation period and density of the sample specimen shall be linear. Before measuring a sample density, the respective intrinsic oscillation periods T_{S1} and T_{S2} for two reference substances (density: ρ_{S1} , ρ_{S2}) must be measured at a specified temperature $t^\circ\text{C}$, and the cell constant K_t ($\text{g}\cdot\text{cm}^{-3}$)

s⁻²) must be determined by using the following equation.

$$K_{t'} = \frac{\rho_{S1}^{t'} - \rho_{S2}^{t'}}{T_{S1}^2 - T_{S2}^2}$$

Usually, water and dried air are chosen as reference substances. Here the density of water at $t'^{\circ}\text{C}$, $\rho_{S1}^{t'}$, is taken from the Table 1, and that of dried air $\rho_{S2}^{t'}$ is calculated by using the following equation, where the pressure of dried air is at p kPa.

$$\rho_{S2}^{t'} = 0.0012932 \times \{273.15 / (273.15 + t')\} \times (p / 101.325)$$

Next, introduce a sample specimen into a sample cell having a cell constant $K_{t'}$, the intrinsic vibration period, T_T , for the sample under the same operation conditions as employed for the reference substances. The density of a sample specimen at $t'^{\circ}\text{C}$, $\rho_T^{t'}$, is calculated by use of the following equation, by introducing the intrinsic oscillation period T_{S1} and the density of water at a specified temperature $t'^{\circ}\text{C}$, $\rho_{S1}^{t'}$, into the equation.

$$\rho_T^{t'} = \rho_{S1}^{t'} + K_{t'}(T_T^2 - T_{S1}^2)$$

Further, the specific gravity of a sample specimen against water at a temperature $t'^{\circ}\text{C}$, $d_t^{t'}$, can be obtained by using the equation below, by introducing the density of water at a temperature $t'^{\circ}\text{C}$, $\rho_w^{t'}$, indicated in Table 1.

$$d_t^{t'} = \frac{\rho_T^{t'}}{\rho_w^{t'}}$$

Apparatus

An oscillator-type density meter is usually composed of a glass tube cell of about 1 mL capacity, the curved end of which is fixed to the vibration plate, an oscillator which applies an initial vibration to the cell, a detector for measuring the intrinsic vibration period, and a temperature controlling system.

A schematic illustration of the apparatus is depicted in Fig. 2.

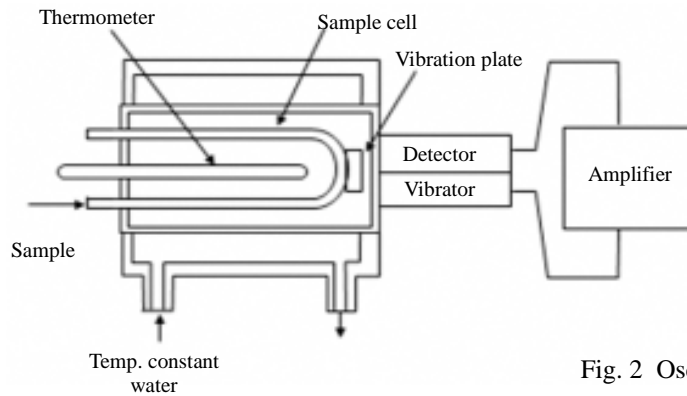

Fig. 2 Oscillator-type density meter

Procedure

A sample cell, water, and a sample specimen are previously adjusted to a specified temperature $t'^{\circ}\text{C}$. Wash the sample cell with water or an appropriate solvent, and dry it thoroughly with a flow of dried air. Stop the flow of dried air, confirm that the temperature is at the specified value, and then measure the intrinsic oscillation period T_{S2} given by the dried air. Separately, the atmospheric pressure p (kPa) must be measured at the time and place of the examination. Next, introduce water into the sample cell and measure the intrinsic oscillation period T_{S1} given by water. Using these values of the intrinsic oscillation period and the atmospheric pressure,

the sample cell constant K_t can be determined by use of the above-mentioned equation.

Next, introduce a sample specimen into the glass cell, confirm the specified temperature, and measure the intrinsic oscillation period T_T given by the sample specimen. Using the intrinsic oscillation periods for water and the sample specimen, the density of water $\rho_{S,T}^t$, and the cell constant K_t , the density of the sample specimen ρ_T^t can be obtained by use of the above equation. If necessary, the specific gravity of the sample specimen d_t^t against water at a temperature $t^\circ\text{C}$, can be calculated by using the density of water ρ_W^t shown in Table 1.

In this measurement, avoid the occurrence of bubble formation in the sample cell, when a sample specimen or water is introduced into the cell.

Method 4: Sink-float method

This method is used to measure the specific gravity of a chemical fiber sample or a plastic sample such as granule, pellet or flake.

(1) Chemical fiber samples

Immerse about 0.1 g of the fiber sample in about 20 mL of an appropriate deoiling liquid shown in Table 2 for about 1 hour. After remove oil, air-dry the sample, cut into 0.5 mm to 1.0 mm pieces using a razor etc., and using a vacuum desiccator with the pressure not exceeding 0.5 kPa dry these pieces completely before use.

Place about 8 mL of the prepared specific gravity determination liquid in the sedimentation tube and put a small amount of the sample in it. Stopper the sedimentation tube, disperse the sample well, centrifuge to expel any entrapped air bubbles and immerse the tube in a water bath maintained at the specified temperature $t^\circ\text{C} \pm 0.1^\circ\text{C}$ for about 30 minutes. Observe whether the sample sinks or floats and add an adequate amount of either heavy or light liquid shown in Table 3 according to its condition to adjust the specific gravity of the specific gravity determination liquid so that the sample reaches equilibrium in the liquid. After adjustment, allow the tube to stand in the water bath for 30 minutes and confirm that the sample exists still in equilibrium in the liquid. Then, measure the specific gravity of the liquid in the cylinder as directed in Methods 1 to 3 and designate it as the specific gravity of the sample (d_t^t).

Specific gravity determination liquid

Mix adequate amounts of a heavy liquid and a light liquid for fiber sample shown in Table 3 in a measuring cylinder so that the specific gravity of the mixture is within ± 0.02 of the expected specific gravity of the sample.

Table 2: Liquids used for deoiling chemical fiber samples

Fiber	Deoiling liquid
Polyester	Methanol
Acetate	Diethyl ether
Polypropylene	Ethanol
Other	Mixture of ethanol and benzene (capacity ratio 1:2)

Table 3: Heavy and light liquids

Fiber	Heavy liquid	Light liquid
Polypropylene	Water	Ethanol
Polyester	Perchloroethylene	n-Heptane
Other	Perchloroethylene	Toluene

(2) Plastic samples such as granules, pellets or flakes

Transfer exactly 100 mL of the prepared specific gravity determination liquid into a 250 mL measuring cylinder and immerse the cylinder in a water bath maintained at $t^{\circ}\text{C} \pm 0.1^{\circ}\text{C}$. Put some of the samples in a cylinder, and sink them to the bottom to avoid formation of bubbles. Allow the cylinder to stand for about 5 minutes and stir several times so that the temperature remains stable at the specified temperature $t^{\circ}\text{C}$. Observe whether the sample sinks or floats and add an adequate amount of either heavy or light liquid according to its condition to adjust the specific gravity of the specific gravity determination liquid so that the sample reaches equilibrium in the liquid. After adjustment, allow the cylinder to stand in the water bath for a while and confirm that the sample exists still in equilibrium. Then, measure the specific gravity of the liquid in the cylinder as directed in Methods 1 to 3 and designate it as the specific gravity of the sample (d_t').

Specific gravity determination liquid

The heavy and light liquids are freshly distilled liquids having different densities, which are compatible and do not dissolve, swell or react with the sample. Mix adequate amounts of a heavy liquid and a light liquid so that the specific gravity of the mixture is within ± 0.02 of the expected specific gravity of the sample, and use as the specific gravity determination liquid at the start of the measurement.

Method 5: Measurement using density gradient tube

When a solid sample is placed in the liquid, it sinks if its density is greater than that of the liquid and it floats if its density is smaller than that of the liquid, and it remains suspended if its density is equal to that of the liquid. The density gradient tube method works on this principle. This method is applicable for a sample having a volume not exceeding 0.5 cm^3 and when the density gradient liquid used for this test does not dissolve, swell or react with the sample.

The density gradient tube is a vertically-placed glass cylinder with graduations, and prepared by injecting two liquids having the different densities while continuously changing the mixing ratio. The relation between the graduation of the density gradient tube and the density should be calibrated using a standard float.

Apparatus

It is shown in Fig. 3.

- Glass cylinder: Use a glass cylinder 1 m in length and having an inside diameter of 4.5 cm, with a stopper on the top, having 1 mm graduation lines along the length of not less than 85 cm and 10 mm graduation lines around the circumference and the figures displayed at intervals of 1, 2 or 5 cm. If appropriate, glass cylinders of different sizes can be used.
- Glass containers: Use two 1000 mL or about 2000 mL glass containers having the same diameter.
- Siphon: Use a siphon as shown in Fig. 3.

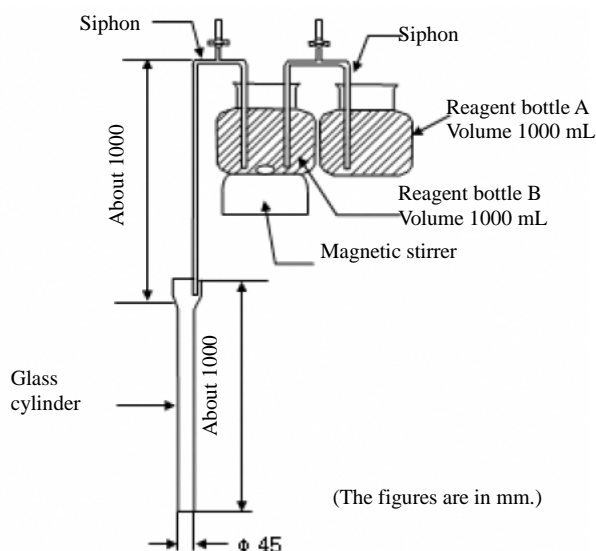

Fig. 3 Density gradient tube

Standard floats

Use hollow glass balls, which are 2 to 5 mm in diameter, the densities of which are accurately determined to the same digit as specified in the required measurement result.

Preparation of density gradient tube

Prepare a density gradient tube as follows.

- a) To determine the densities ρ_A and ρ_B ($\rho_A < \rho_B$) of two liquids which consist of the density gradient liquid by using the following equation.

$$\rho_A = \rho_B - \frac{2(\rho_B - \rho) \times V_B}{V}$$

ρ_A : Initial density (g/cm^3) of the liquid in glass container A

ρ_B : Initial density (g/cm^3) of the liquid in glass container B

ρ : Density (g/cm^3) of the liquid in the uppermost part of the density gradient tube

V_B : Initial volume (mL) of the liquid in glass container B

V : Total volume (mL) of the liquid in the density gradient tube

When measurements down to the third decimal place are required, prepare a density gradient tube of which density difference between the tube bottom and tube top does not exceeding 0.2 g/cm^3 .

- b) Prepare two liquids having the densities specified in a) according to Tables 3, 4, and 5 and determine their densities according to Methods 1 to 3. Sufficiently deaerated liquid is used. When water is used, it is boiled or decompressed before use.
- c) Place the liquid of a lower density in the glass container A in Fig. 3 and the liquid of a higher density in the glass container B, make the level of both liquid equal, and connect with a siphon filled with the liquid of a lower density.
- d) While stirring the liquid in the glass container B with a stirrer, inject the liquid in the container into the glass cylinder along the wall of the cylinder at the rate of 20 mL/min or lower using a siphon.
- e) Perform procedures b) to d) at the specified temperature $t^\circ\text{C}$.
- f) Stopper the glass cylinder, place it slowly in a water bath maintained at the specified temperature $t^\circ\text{C}$,

and allow to stand for not less than 1 hour. When measurements down to the third decimal place are required, allow the density gradient tube to stand in a water bath maintained at $t^{\circ}\text{C} \pm 0.5^{\circ}\text{C}$.

- g) Wet a standard float with the liquid in the glass container A, place it gently in the cylinder, stopper it, and use this as the density gradient tube. When measurements down to the third decimal place are required, more than one standard floats are appropriate per density difference of 0.01.
- h) After 24 hours, read the height of the gravity center of the standard float in the density gradient tube to 1 mm from graduations of the density gradient tube, and prepare a calibration curve indicating the relation between the density of the standard float and the graduation of the density gradient tube. The accuracy of the calibration curve should be ± 1 mm.
- i) If the calibration curve is not a smooth curve or markedly curved, repeat the above procedures from a) to h).

Density gradient liquid

A density gradient liquid should not dissolve or swell a solid sample. The two liquids which consist of a density gradient liquid should be compatible. Representative examples of density gradient liquids and the applicable density range are shown in Table 4. Reagents for density adjustment used for various mixtures are shown in Table 5.

Table 4 Examples of density gradient liquids

Liquids	Density range (g/cm ³)
Methanol / Benzyl alcohol	0.80-0.92
2-Propanol / Water	0.79-1.00
2-Propanol / Diethylene glycol	0.79-1.11
Ethanol / Carbon tetrachloride	0.79-1.59
Ethanol / Water	0.79-1.00
Toluene / Carbon tetrachloride	0.87-1.59
Water / Sodium bromide	1.00-1.41
Water / Calcium nitrite	1.00-1.60
Zinc chloride / Ethanol / Water	0.80-1.70
Carbon tetrachloride / 1,3-Dibromopropane	1.60-1.99
1,3-Dibromopropane / Ethylene bromide	1.99-2.18
Ethylene bromide / Bromoform	2.18-2.89
Carbon tetrachloride / Bromoform	1.60-2.89
2-Propanol / Methyl glycol acetate	0.79-1.00

Table 5 Examples of reagents for density adjustment

Reagent name	Density (g/cm ³)
n-Octane	0.70
Dimethylformamide	0.94
Ethane tetrachloride	1.59
Ethyl iodide	1.93

Procedure

Dry the sample sufficiently, prepare 3 samples from the identical sample, and used these samples as the samples for measurement. The samples should be stored in a desiccator with a desiccant. The length of the largest part of each sample should be not more than one-fourth the inside diameter of the density gradient tube and the volume of each sample should be not more than 0.5 cm^3 (usually, 2 to 5 mm \times 2 to 5 mm). If the sample is a chemical fiber, deoil the sample as directed in Method 4, air-dry, and tie in a ring having a diameter of 3 mm.

When multiple samples are put in simultaneously and measured using the existing calibration curve, the size of each sample should be adjusted so that the increased level of liquid surface due to charge-in of all samples should not exceed 1 mm.

Wet three samples with the liquid having a lower density and place them gently in the density gradient tube, taking care to avoid formation of air bubbles. If the samples are fiber, allow the samples in the liquid with a low density to stand under reduced pressure of 0.7 kPa for 5 minutes or centrifuge at 2000 to 3000 min^{-1} for 2 to 3 minutes to expel any entrapped air bubbles.

After the sample reaches equilibrium and exists still, read the level of the gravity center to 1 mm from graduations of the density gradient tube. If the sample contacts with the standard float or the inner wall of the tube, perform the test again. Compare the readings and calibration curve, read the density corresponding to each sample to the same digit number as required accuracy.

Determine the mean density, $\rho_T^{t'}$ of three samples at the specified temperature $t'^\circ\text{C}$, designate it as the density of the sample and round off to the same decimal place as that of the calibration density of the standard float. If the density gradient per mm of the density gradient tube exceeds the change in one, the last digit of the calibration density of the standard float, round off to one place higher than that of the calibration density of the standard float. Calculate the specific gravity of the sample $d_i^{t'}$ by using the following equation from the density determined above and the density of water ρ_W^t at $t^\circ\text{C}$ in Table 1, and round off to the same decimal place as that of the density.

$$d_i^{t'} = \frac{\rho_T^{t'}}{\rho_W^t}$$

19. Arsenic Limit Test

Arsenic Limit Test is a limit test for arsenic contained in a sample. The limit is expressed in terms of arsenic (III) trioxide (As_2O_3). In each monograph, the permissible limit for arsenic (as As_2O_3) is described in terms of ppm in parentheses.

Apparatus

Use the apparatus shown in the figure.

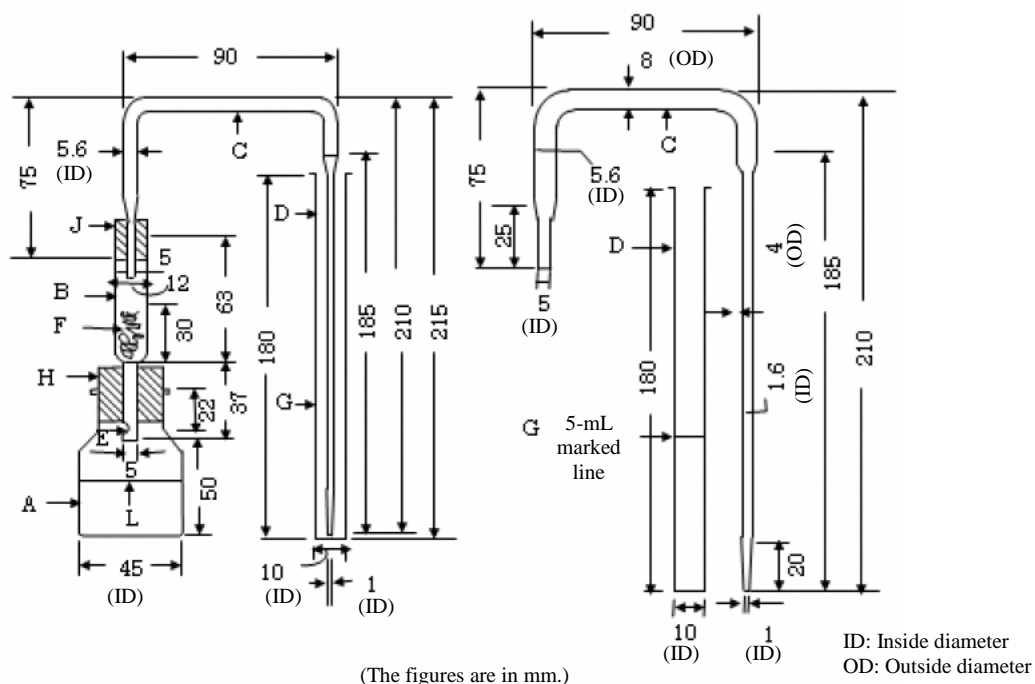

Figure Arsenic limit test apparatus

- A: Generator bottle (capacity up to the shoulder: about 70 mL)
- B: Exit tube
- C: Glass tube (inside diameter: 5.6 mm, the tip of the part to be inserted in the absorber tube D is drawn out to 1 mm in diameter)
- D: Absorber tube (inside diameter: 10 mm)
- E: Small perforation
- F: Glass wool (about 0.2 g)
- G: 5-mL marked line
- H and J: Rubber stoppers
- L: 40-mL marked line

Place glass wool F in the exit tube B up to about 30 mm in height, moisten the glass wool uniformly with a mixture of an equal volume of lead (II) acetate TS and water, and apply gentle suction to the lower end to remove the excess of the mixture. Insert the tube vertically into the center of the rubber stopper H, and attach the tube to the generator bottle A so that the small perforation E in the lower end of B extends slightly below. At the upper end of B, attach the rubber stopper J to hold the tube C vertically. Make the lower end to the exit tube of C level with that of the rubber stopper J.

Preparation of sample solution

Unless otherwise specified, proceed by the following method.

Method 1

Unless otherwise specified, weigh 1.0 g of the sample, add 5 mL of water, dissolve by heating if necessary, and designate the solution as the sample solution.

Method 2

Unless otherwise specified, weigh 1.0 g of the sample, and place it in a crucible of platinum, quartz, or porcelain. Add 10 mL of a solution of magnesium nitrate hexahydrate in ethanol (95) (1 in 50), ignite the ethanol, and heat gradually to incinerate. If a carbonized residue still remains, moisten the residue with a little amount of nitric acid, and ignite again to incinerate. After cooling, add 3 mL of hydrochloric acid, heat on a water bath to dissolve the residue, and designate it as the sample solution.

Test solutions

Absorbing solution for hydrogen arsenide: Dissolve 0.50 g of silver N,N-diethyldithiocarbamate in pyridine to make 100 mL. Preserve this solution in a glass-stoppered bottle protected from light, in a cold place.

Standard Arsenic Stock Solution: Weigh accurately 0.100 g of finely powdered arsenic (III) trioxide dried at 105°C for 4 hours, and add 5 mL of sodium hydroxide solution (1 in 5) to dissolve. Add dilute sulfuric acid to neutralize, add further 10 mL of dilute sulfuric acid, and add freshly boiled and cooled water to make exactly 1000 mL.

Standard Arsenic Solution: Pipet 10 mL of Standard Arsenic Stock Solution, add 10 mL of dilute sulfuric acid, and add freshly boiled and cooled water to make exactly 1000 mL. Each mL of the solution contains 1 µg of arsenic (III) trioxide (As₂O₃). Prepare before use and preserve in a glass-stoppered bottle.

Procedure

Unless otherwise specified, proceed using apparatus shown in Figure.

Carry out the preparation of the standard color at the same time.

Place the sample solution in the generator bottle A, and, if necessary, wash down the solution in the bottle with a small quantity of water. Add 1 drop of methyl orange TS, and after neutralizing with ammonia TS, ammonia solution (28), or dilute hydrochloric acid, add 5 mL of diluted hydrochloric acid (1 in 2) and 5 mL of potassium iodide TS, and allow to stand for 2 to 3 minutes. Add 5 mL of acidic tin (II) chloride TS, and allow to stand for 10 minutes. Then add water to make 40 mL, add 2 g of zinc for arsenic analysis, and immediately connect the rubber stopper H fitted with B and C with the generator bottle A. Transfer 5 mL of the absorbing solution for hydrogen arsenide to the absorber tube D, insert the tip of C to the bottom of the absorber tube D, then, immerse the generator bottle A up to the shoulder in water maintained at 25°C and allow to stand for 1 hour. Disconnect the absorber tube, add pyridine to make 5 mL if necessary, and observe the color of the absorbing solution: the color produced is not more intense than the standard color.

Preparation of standard color: Measure accurately 2 mL of Standard Arsenic Solution in the generator bottle A. Add 5 mL of diluted hydrochloric acid (1 in 2) and 5 mL of potassium iodide TS, and allow to stand for 2 to 3 minutes. Add 5 mL of acidic tin (II) chloride TS, allow to stand at room temperature for 10 minutes, and then proceed as directed above. The color produced corresponds to 2 µg of arsenic (III) trioxide (As₂O₃) and is used as the standard.

Note: Apparatus, reagents, and test solutions used in the test should contain little or no arsenic. If necessary, perform a blank determination.

20. Melting Point Determination

The melting point is defined to be the temperature at which a crystalline substance melts during heating, when the solid phase and the liquid phase are in an equilibrium. However, it is conventionally defined to be the temperature at which the remaining solid sample melts completely when it is subjected to continuous heating and the change of the sample state that accompanies heating is accurately observed. Since a pure substance has an intrinsic melting point, it is used for the identification and/or confirmation of a substance and also as an indicator of the purity of a substance.

The melting point is the temperature measured by either of the following methods. Method 1 is applied to those substances of which the purity is comparably high and which can be pulverized, Method 2 to those substances which are insoluble in water and can not be readily pulverized, and Method 3 can be applied to polymer resins or synthetic fibers.

Method 1

This method is applied to those substances of which the purity is comparably high and which can be pulverized.

Apparatus

Use as shown in the figure. Alternatively, apparatus in which some of the procedures, such as stirring, heating, and cooling are automated, can be used.

Bath fluid: Usually use clear silicone oil having a viscosity of 50 to 100 mm²/s at an ordinary temperature.

Thermometer with an immersion line: There are six types of thermometers, Type 1- Type 6, which are specified by an appropriate measuring temperature range. For melting points lower than 50°C, use a thermometer Type 1; for 40°C to 100°C, Type 2; for 90°C to 150°C, Type 3; for 140°C to 200°C, Type 4; for 190°C to 250°C, Type 5; for 240°C to 320°C, Type 6.

Capillary tube: Use a hard glass capillary tube 120 mm long, 0.8 to 1.2 mm in inner diameter and 0.2 to 0.3 mm thick, with one end closed.

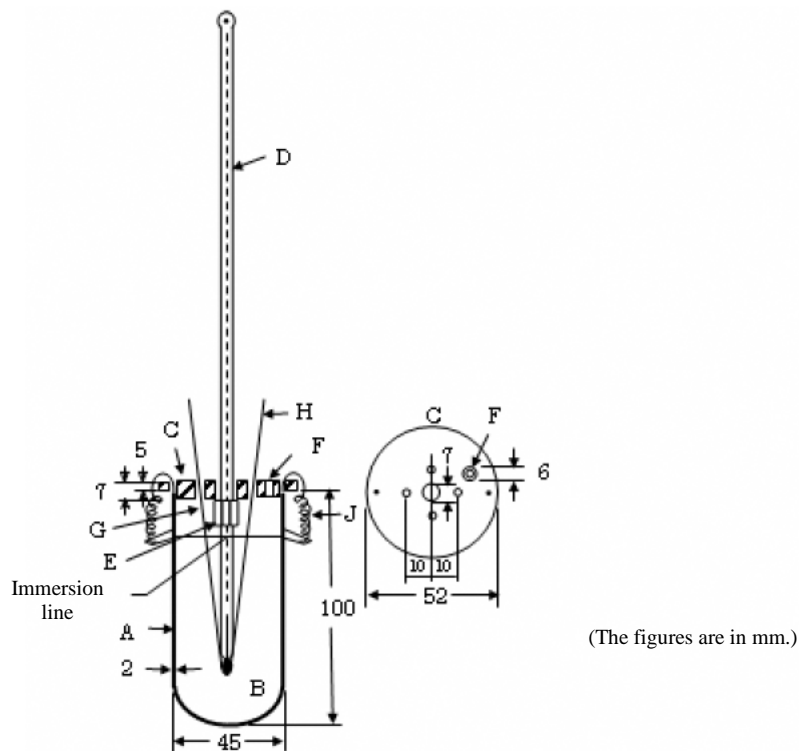

Figure Melting point determination device

- A: Heating vessel of hard glass
- B: Bath fluid
- C: Teflon stopper
- D: Thermometer with an immersion line
- E: Thermometer-fastening spring
- F: Vent for adjustment of the bath fluid volume
- G: Coil spring
- H: Capillary tube
- J: Spring for fastening Teflon stopper

Procedure

Pulverize the sample to a fine powder, and, unless otherwise specified, dry in a desiccator (silica gel) for 24 hours. When it is specified to do the test after drying, dry the sample under the conditions specified in the monograph before measurement.

Place the sample in a dried capillary tube H, and pack it tightly so as to form a layer about 2.5-3.5 mm high by dropping the capillary repeatedly, with the closed end of H down, through a glass tube, about 70 cm long, held vertically on a glass or porous plate.

Heat the bath fluid B until the temperature rises to about 10°C below the expected melting point, place the thermometer D in the bath with the immersion line at the same level as the meniscus of the bath fluid, and insert capillary tube H into a coil spring G so that the packed sample is placed in a position corresponding to the center of the mercury bulb of the thermometer D. Continue heating to raise the temperature at a rate of

approximately 3°C per minute until the temperature rises to 5°C below the expected melting point, then carefully regulate the rate of temperature increase to 1°C per minute.

Read the thermometer indication of the instantaneous temperature at which the sample liquefies completely and no solid is detectable in the capillary, and designate the indicated temperature as the melting point of the sample specimen.

System suitability test

Confirmation of the system suitability of the apparatus should be done periodically by using the Melting Point Standards. The Reference Standard is prepared for the suitability test of the apparatus when it is used with Type 2 - Type 5 thermometers, and consists of 6 highly purified substances: acetanilide, acetophenetidine, caffeine, sulfanilamide, sulfapyridine, and vanillin. The label shows the certified melting points of the respective substances (the end point of the melting change), *MP_f*. After selecting one of the thermometers and the appropriate Melting Point Standard based upon the expected melting point of a sample specimen, perform a melting point measurement of the selected Reference Standard, according to the above procedure. When the value of the obtained melting point of the Reference Standard is within $MP_f \pm 0.5^\circ\text{C}$ in the case of vanillin and acetanilide, within $MP_f \pm 0.8^\circ\text{C}$ in the case of acetophenetidine and sulfanilamide, and within $MP_f \pm 1.0^\circ\text{C}$ in the case of sulfapyridine and caffeine, the apparatus is assumed to be suitable. The above-mentioned measurement is repeated 3 times and the average is determined to be the melting point of the Reference Standard tested.

When the above suitability test criteria are not met in a certain melting point measurement system of an apparatus and a Reference Standard, do the test again, after checking the packing of the sample specimen into the capillary tube, the locations and positioning of the thermometer and the capillary tube, the heating and stirring of the bath fluid, and the control of the temperature increasing rate. When a melting point measurement system does not meet the suitability test criteria again after checking these measuring conditions, the thermometer with an immersion line should be calibrated again or replaced with a new one.

Method 2

This method is applied to substances such as fats, fatty acids, paraffins or waxes.

Apparatus

Instead of the apparatus specified in Method 1, use a water-containing beaker as a bath fluid and a heating vessel. In this measurement, total immersion mercury-filled thermometers can also be used in place of the thermometer with an immersion line. Furthermore, the capillary tube should be the same as specified in Method 1, except that both ends of the tube are open.

Procedure

Carefully melt the sample at as low a temperature as possible, and, taking care to prevent bubbles, introduce it into a capillary tube to a height of about 10 mm. Allow the capillary containing the sample to stand for 24 hours at below 10°C, or for at least 1 hour in contact with ice, holding the capillary so that the sample can not flow out. Then attach the capillary to the thermometer by means of a rubber band so that the absorbed sample is located at a position corresponding to the center of the mercury bulb. Adjust the capillary tube in a water-containing beaker to such a position that the lower edge of the sample is located 30 mm below the water surface. Heat the beaker with constant stirring until the temperature rises to 5°C below the expected melting point. Then regulate the rate of temperature increase to 1°C per minute. The temperature at which the sample begins floating in the capillary is taken as the melting point of the sample specimen.

Method 3

Melting point can be determined by “Thermal Analysis”, either “Differential Thermal Analysis (DTA)” or “Differential Scanning Calorimetry (DSC)”.

Thermal Analysis is a generic term for a variety of techniques to measure the physical properties of a substance as a function of temperature and/or time.

Among the physical properties, phase transitions such as solid/liquid phase transition (melting, freezing) and crystal polymorphism or thermal behavior such as heat evolution or absorption accompanying thermal degradation or chemical reaction can be detected by the techniques of differential thermal analysis (DTA) or differential scanning calorimetry (DSC).

DTA is a method for detecting the thermal behavior of a specimen in terms of the temperature change, while DSC employs the heat quantity (enthalpy) change.

Apparatus

Apparatus for DTA or DSC is usually composed of a heating furnace, a temperature-controller, a detector, a device for controlling the atmosphere, and an indicator/recorder.

In a DTA apparatus, a sample specimen and an inert reference material placed in the heating furnace are heated or cooled at a constant rate, and the temperature difference evolved between the sample and reference material is detected continuously by a device such as a thermocouple and recorded as a function of time and/or temperature. As an inert reference material, α -Alumina for thermal analysis is usually adopted.

Two kinds of DSC apparatus, based upon different principles are available as shown below.

(1) Input compensation-type differential scanning calorimetry (Input compensation DSC)

A sample specimen and the reference material in twin furnaces are programmed to be heated or cooled at a constant rate, and the temperature difference between the sample and the reference, which is detected by a device such as a platinum resistance thermometer, is kept at null by controlling the heating unit with a compensation feed-back circuit. The instrument is designed to measure and record continuously the balance of thermal energy applied to each furnace as a function of temperature and/or time.

(2) Heat flux-type differential scanning calorimetry (Heat flux DSC)

A sample specimen and the reference material in twin furnaces are programmed to be heated or cooled at a constant rate, and the temperature difference between the sample and the reference is detected as a difference of heat flux and recorded as a function of temperature and/or time. In heat flux DSC, thermal conductors are adopted so that the heat flux between the sample and the heat reservoir is proportional to the temperature difference between them.

In usual DSC analysis, α -Alumina is used as a reference material, both in Input compensation DSC and in Heat flux DSC. But in some cases, an empty sample container can also be used without any reference material.

Procedure

A sample specimen and the reference material are put in sample pans, and the furnace is heated or cooled under a controlled temperature program. As the temperature changes, the temperature difference (DTA) or heat quantity change (DSC) that develops between the specimen and the reference is detected and recorded

continuously. Apparatus equipped with a data-processor is operated according to the instruction manual provided with the instrument.

A preliminary experiment is needed to determine the appropriate temperature range of measurement, within which a predicted physical change such as melting or polymorphic phase transition will occur, and to confirm that unpredicted thermal changes are not induced in a specimen in that temperature range. In this preliminary test, a wide temperature range (room temperature-the temperature at which degradation begins) can be scanned at a rapid heating rate (10-20°C/min). Thereafter, tests by DSC or DTA should be performed at a low heating rate, usually 2°C/min, in the chosen temperature range. However, when a clear heat change cannot be observed, such as in a case of glass-transition, the heating rate may be changed to a higher or a lower rate, as appropriate for the kind of physical change being observed. By analyzing the measured DTA-curve or DSC-curve, a quantity of heat change and/or a specific temperature (ignition, peak or end temperature) that accompanies a physical change, such as melting or polymorphic phase transition, can be obtained.

Calibration of apparatus

(1) Temperature calibration

Temperature calibration for DTA and/or DSC apparatus can be performed by using reference substances having an intrinsic thermal property, such as melting point of pure metals or organic substances, or phase transition point of crystalline inorganic salts or oxides. Melting points of Indium for thermal analysis and/or Tin for thermal analysis are usually employed for calibration.

(2) Heat-quantity calibration for DSC

For accurate estimation of a quantity of heat change (enthalpic change) of a sample specimen, caused by a certain physical change accompanying a temperature change, it is necessary to calibrate the apparatus by using appropriate reference substances. As indicated in the section of Temperature calibration, heat-quantity calibration for DSC apparatus can be performed by using appropriate reference substances having a known definite enthalpic change caused by such physical changes as melting of pure metals and/or organic substances, or phase transition of crystalline inorganic salts. Melting points of Indium for thermal analysis and/or Tin for thermal analysis are usually employed for calibration.

Notes on operating conditions

When DTA or DSC measurements are made, the following items must be recorded: sample size, discrimination of open or closed-type sample container, heating or cooling rate, measuring temperature range, and kind and flow rate of atmospheric gas.

21. Readily Carbonizable Substances Test

Readily Carbonizable Substances Test is a method to examine the minute impurities contained in samples, which are readily colored by addition of sulfuric acid.

Procedure

Use 94.5% to 95.5% sulfuric acid (sulfuric acid for readily carbonizable substances). Before use, wash the Nessler tubes thoroughly with sulfuric acid. Unless otherwise specified, proceed as follows. When the sample

is solid, place 5 mL of sulfuric acid in a Nessler tube, to which add a quantity of the finely powdered sample, little by little, as directed in the monograph, and dissolve it completely by stirring with a glass rod. When the sample is liquid, transfer a volume of the sample, as directed in the monograph, to a Nessler tube, add 5 mL of sulfuric acid, and mix by shaking. If the temperature of the content of the tube rises, cool the content; maintain it at the standard temperature, if the reaction may be affected by the temperature. Allow to stand for 15 minutes, and compare the color of the liquid with that of the matching fluid in the Nessler tube specified in the monograph, by viewing transversely against a white background.

When it is specified to heat the sample with sulfuric acid, transfer the sample and sulfuric acid to a Nessler tube, heat as specified, and compare the colors.

22. Standard Solutions, Matching Fluids for Color, Reference Standards, Reagents, Test Solutions, Measuring Instruments and Appliances

Standard Solutions for Volumetric Analysis are the solutions of reagent with an accurately known concentration, mainly used for the volumetric analysis.

Standard Solutions are used as the standard for the comparison in the tests specified in the JSNM.

Matching Fluids for Color are used as the reference for the comparison of color in the tests specified in the JSNM.

Reference Standards are the substances prepared to a specified purity or quality necessary with regard to their intended use as prescribed in monographs of the JSNM.

Reagents are the substances used for the tests specified in the JSNM. The reagents that are described as “standard reagent”, “special class”, “first class”, “for pH determination”, etc. in the JSNM meet the corresponding specifications under the Japan Industrial Standards (JIS). The tests for them shall be performed according to the test methods under the JIS. In the case where the reagent names in the JSNM differ from those of the JIS, the JIS names are given in the brackets. The reagents that are described as “JP reference standard” or “JP monograph” meet the specifications of the corresponding reference standards or monographs. In the case of the reagents that are described merely as test items, the corresponding test methods of the JP are to be applied.

Test Solutions are the solutions prepared for use in the tests of the JSNM.

Measuring Instruments are the instruments or machines used for measuring mass or volume in the tests of the JSNM.

Appliances are the instruments specified in order to make test conditions as consistent as possible in the tests of the JSNM.

(1) Volumetric Standard Solutions (VS)

Hydrochloric Acid, 0.5 mol/L

1000 mL of this solution contains 18.230 g of hydrochloric acid (HCl: 36.46).

Preparation: Dilute 45 mL of hydrochloric acid with water to make 1000 mL, and standardize the solution as follows:

Standardization: Weigh accurately about 0.5 g of sodium carbonate (standard reagent), previously heated between 500°C and 650°C for 40 to 60 minutes and allowed to cool in a desiccator (silica gel). Dissolve it in 50 mL of water, and titrate with the prepared hydrochloric acid to calculate the molarity factor (indicator: 3 drops of methyl red TS). In the indicator method, when the end point is approached, boil the solution carefully, stopper the flask loosely, allow to cool, and continue the titration until the color of the solution changes to persistent orange to orange-red.

Each mL of 0.5 mol/L hydrochloric acid VS = 26.50 mg of Na₂CO₃

Hydrochloric Acid, 0.2 mol/L

1000 mL of this solution contains 7.292 g of hydrochloric acid (HCl: 36.46).

Preparation: Dilute 18 mL of hydrochloric acid with water to make 1000 mL, and standardize the solution as follows:

Standardization: Weigh accurately about 0.15 g of sodium carbonate (standard reagent), previously heated between 500°C and 650°C for 40 to 60 minutes and allowed to cool in a desiccator (silica gel). Dissolve it in 30 mL of water, and titrate the solution with the prepared hydrochloric acid to calculate the molarity factor (indicator: 3 drops of methyl red TS). In the indicator method, when the end point is approached, boil the solution carefully, stopper the flask loosely, allow to cool, and continue the titration until the color of the solution changes to persistent orange to orange-red.

Each mL of 0.2 mol/L hydrochloric acid VS = 10.60 mg of Na₂CO₃

Hydrochloric Acid, 0.1 mol/L

1000 mL of this solution contains 3.6461 g of hydrochloric acid (HCl: 36.46).

Preparation: Before use, dilute 0.2 mol/L hydrochloric acid VS with water to make exactly 2 times the initial volume.

Each mL of 0.1 mol/L hydrochloric acid VS = 5.300 mg of Na₂CO₃

Hydrochloric Acid, 0.01 mol/L

1000 mL of this solution contains 0.36461 g of hydrochloric acid (HCl: 36.46).

Preparation: Before use, dilute 0.2 mol/L hydrochloric acid VS with water to make exactly 20 times the initial volume.

Potassium Permanganate, 0.02 mol/L

1000 mL of this solution contains 3.1607 g of potassium permanganate (KMnO₄: 158.03).

Preparation: Dissolve 3.2 g of potassium permanganate in water to make 1000 mL, and boil the solution for 15 minutes. Allow the solution to stand for at least 48 hours in a tightly stoppered flask, and filter it through a glass filter (G3 or G4). Standardize the solution as follows:

Standardization: Weigh accurately about 0.3 g of sodium oxalate (standard reagent), previously dried between 150°C and 200°C for 1 to 1.5 hours and allowed to cool in a desiccator (silica gel), transfer it to a 500 mL conical flask, dissolve in 30 mL of water, add 250 mL of diluted sulfuric acid (1 in 20), and warm the mixture between 30°C and 35°C. Transfer the prepared potassium permanganate solution to a burette, add quickly 40 mL of the solution under gentle stirring from the burette, and allow to stand until the red color of the mixture disappears. Warm the solution between 55°C and 60°C, and complete the titration with the potassium permanganate solution until a faint red color persists for 30 seconds. Add the last 0.5 to 1 mL dropwise before the end point, being particularly careful to allow the solution to be decolorized before the next drop is added. Calculate the molarity factor.

Each mL of 0.02 mol/L potassium permanganate VS = 6.700 mg of Na₂C₂O₄

Note: Store protected from light. This solution, if stored for a long period, should be restandardized.

Potassium Permanganate, 0.002 mol/L

1000 mL of this solution contains 0.31607 g of potassium permanganate (KMnO₄: 158.03).

Preparation: Before use, dilute 0.02 mol/L potassium permanganate VS with water to make exactly 10 times

the initial volume.

Potassium Hydroxide, 0.1 mol/L

1000 mL of this solution contains 5.611 g of potassium hydroxide (KOH: 56.11).

Preparation: Dissolve 6.5 g of potassium hydroxide in 950 mL of water. Add a freshly prepared, saturated solution of barium hydroxide octahydrate until no more precipitate is produced. Shake the mixture thoroughly, and allow it to stand for 24 hours in a tightly stoppered bottle. Decant the supernatant liquid or filter the solution through a glass filter (G3 or G4), and standardize the solution as follows:

Standardization: Weigh accurately about 0.25 g of amidosulfuric acid (sulfamic acid)(standard reagent), previously dried in a desiccator (in vacuum, silica gel) for 24 to 48 hours. Dissolve it in 25 mL of freshly boiled and cooled water, and add 2 drops of bromothymol blue TS. Titrate with the prepared potassium hydroxide solution until it acquires a green color. Calculate the molarity factor.

Each mL of 0.1 mol/L potassium hydroxide VS =9.709 mg of HOSO₂NH₂

Note: Store in tightly stoppered bottles or in containers provided with a carbon dioxide-absorbing tube (soda lime). This solution, if stored for a long period, should be restandardized.

Potassium Hydroxide-Ethanol, 0.5 mol/L

1000 mL of this solution contains 28.055 g of potassium hydroxide (KOH: 56.11).

Preparation: Dissolve 35 g of potassium hydroxide in 20 mL of water, and add aldehyde-free ethanol to make 1000 mL. Allow the solution to stand for 24 hours in a tightly stoppered bottle. Then quickly decant the supernatant liquid, and standardize the solution as follows:

Standardization: Measure exactly 25 mL of 0.25 mol/L sulfuric acid VS, add 50 mL of water, and titrate with the prepared potassium hydroxide-ethanol solution to calculate the molarity factor (indicator: 2 drops of phenolphthalein TS). In the indicator method, titrate until the solution acquires a light red color.

Note: Store in tightly stoppered bottles, protected from light. Standardize before use.

Potassium Hydroxide-Ethanol, 0.1 mol/L

1000 mL of this solution contains 5.611 g of potassium hydroxide (KOH: 56.11).

Preparation: Dissolve 7 g of potassium hydroxide in 20 mL of water, and add aldehyde-free ethanol to make 1000 mL. Allow the solution to stand for 24 hours in a tightly stoppered bottle. Then quickly decant the supernatant liquid, and standardize the solution as follows:

Standardization: Measure exactly 15 mL of 0.05 mol/L sulfuric acid VS, add 50 mL of water, and titrate with the prepared potassium hydroxide-ethanol solution to calculate the molarity factor (indicator: 2 drops of phenolphthalein TS). In the indicator method, titrate until the solution acquires a light red color.

Note: Store in tightly stoppered bottles, protected from light. Standardize before use.

Sodium Hydroxide, 1 mol/L

1000 mL of this solution contains 39.997 g of sodium hydroxide (NaOH: 40.00).

Preparation: Dissolve 42 g of sodium hydroxide in 950 mL of water. Add a freshly prepared, saturated solution of barium hydroxide octahydrate until no more precipitate is produced. Mix well the mixture, and allow to stand for 24 hours in a tightly stoppered bottle. Decant the supernatant liquid or filter the solution through a glass filter (G3 or G4), and standardize the solution as follows:

Standardization: Weigh accurately about 1.5 g of amidosulfuric acid (sulfamic acid)(standard reagent),

previously dried in a desiccator (in vacuum, silica gel) for 24 to 48 hours. Dissolve it in 25 mL of freshly boiled and cooled water, and titrate the solution with the prepared sodium hydroxide solution to calculate the molarity factor (indicator method: 2 drops of bromothymol blue TS). In the indicator method, titrate until the solution acquires a green color.

Each mL of 1 mol/L sodium hydroxide VS = 97.09 mg of HOSO_2NH_2

Note: Store in tightly stoppered bottles or in containers provided with a carbon dioxide-absorbing tube (soda lime). This solution, if stored for a long period, should be restandardized.

Sodium Hydroxide, 0.5 mol/L

1000 mL of this solution contains 19.999 g of sodium hydroxide (NaOH: 40.00).

Preparation: Dissolve 22 g of sodium hydroxide in 950 mL of water. Add a freshly prepared, saturated solution of barium hydroxide octahydrate until no more precipitate is produced. Mix well the mixture, and allow to stand for 24 hours in a tightly stoppered bottle. Decant the supernatant liquid or filter the solution through a glass filter (G3 or G4), and standardize the solution as follows:

Standardization: Weigh accurately about 0.7 g of amidosulfuric acid (sulfamic acid) (standard reagent), previously dried in a desiccator (in vacuum, silica gel) for 24 to 48 hours. Dissolve it in 25 mL of freshly boiled and cooled water, and titrate the solution with the prepared sodium hydroxide solution to calculate the molarity factor (indicator method: 2 drops of bromothymol blue TS). In the indicator method, titrate until the solution acquires a green color.

Each mL of 0.5 mol/L sodium hydroxide VS = 48.55 mg of HOSO_2NH_2

Note: Store in tightly stoppered bottles or in containers provided with a carbon dioxide-absorbing tube (soda lime). This solution, if stored for a long period, should be restandardized.

Sodium Hydroxide, 0.1 mol/L

1000 mL of this solution contains 3.9997 g of sodium hydroxide (NaOH: 40.00).

Preparation: Dissolve 4.5 g of sodium hydroxide in 950 mL of water. Add a freshly prepared, saturated solution of barium hydroxide octahydrate until no more precipitate is produced. Mix well the mixture, and allow to stand for 24 hours in a tightly stoppered bottle. Decant the supernatant liquid or filter the solution through a glass filter (G3 or G4), and standardize the solution as follows:

Standardization: Weigh accurately about 0.15 g of amidosulfuric acid (sulfamic acid) (standard reagent), previously dried in a desiccator (in vacuum, silica gel) for 24 to 48 hours. Dissolve it in 25 mL of freshly boiled and cooled water, and titrate the solution with the prepared sodium hydroxide solution to calculate the molarity factor (indicator method: 2 drops of bromothymol blue TS). In the indicator method, titrate until the solution acquires a green color.

Each mL of 0.1 mol/L sodium hydroxide VS = 9.709 mg of HOSO_2NH_2

Note: Store in tightly stoppered bottles or in containers provided with a carbon dioxide-absorbing tube (soda lime). This solution, if stored for a long period, should be restandardized.

Sodium Thiosulfate, 0.2 mol/L

1000 mL of this solution contains 49.636 g of sodium thiosulfate pentahydrate ($\text{Na}_2\text{S}_2\text{O}_3 \cdot 5\text{H}_2\text{O}$: 248.18).

Preparation: Dissolve 52 g of sodium thiosulfate and 0.2 g of anhydrous sodium carbonate in freshly boiled and cooled water to make 1000 mL, and standardize the solution as follows:

Standardization: Weigh accurately about 0.2 mg of potassium iodate (standard reagent), previously dried between 120°C and 140°C for 2 hours and allowed to cool in a desiccator (silica gel), and transfer to an iodine flask. Dissolve it in 25 mL of water, add 4 g of potassium iodide and 10 mL of dilute sulfuric acid, and stopper the flask. After allowing the mixture to stand for 10 minutes, add 100 mL of water, and titrate the liberated iodine with the prepared sodium thiosulfate solution to calculate the molarity factor. When the solution assumes a pale yellow color as the end point is approached, add 3 mL of starch TS. Continue the titration until the blue color disappears. Perform a blank determination in the same manner, and make any necessary correction.

Each mL of 0.2 mol/L sodium thiosulfate VS = 7.133 mg of KIO_3

Note: This solution, if stored for a long period, should be restandardized.

Sodium Thiosulfate, 0.1 mol/L

1000 mL of this solution contains 24.818 g of sodium thiosulfate pentahydrate ($\text{Na}_2\text{S}_2\text{O}_3 \cdot 5\text{H}_2\text{O}$: 248.18).

Preparation: Before use, dilute 0.2 mol/L sodium thiosulfate VS with freshly boiled and cooled water to make 2 times the initial volume.

Sodium Thiosulfate, 0.01 mol/L

1000 mL of this solution contains 2.4818 g of sodium thiosulfate pentahydrate ($\text{Na}_2\text{S}_2\text{O}_3 \cdot 5\text{H}_2\text{O}$: 248.18).

Preparation: Before use, dilute 0.2 mol/L sodium thiosulfate VS with freshly boiled and cooled water to make 20 times the initial volume.

Sulfuric Acid, 0.25 mol/L

1000 mL of this solution contains 24.520 g of sulfuric acid (H_2SO_4 : 98.08).

Preparation: Add slowly, under stirring, 15 mL of sulfuric acid to 1000 mL of water, allow to cool, and standardize the solution as follows:

Standardization: Weigh accurately about 0.4 g of sodium carbonate (standard reagent), previously heated between 500°C and 650°C for 40 to 60 minutes and allowed to cool in a desiccator (silica gel). Dissolve it in 50 mL of water, and titrate with the prepared sulfuric acid to calculate the molarity factor (indicator: 3 drops of methyl red TS). In the indicator method, when the end point is approached, boil the solution carefully, stopper the flask loosely, allow to cool, and continue the titration until the color of the solution changes to persistent orange to orange-red.

Each mL of 0.25 mol/L sulfuric acid VS= 26.50 mg of Na_2CO_3

Sulfuric Acid, 0.05 mol/L

1000 mL of this solution contains 4.904 g of sulfuric acid (H_2SO_4 : 98.08).

Preparation: Add slowly, under stirring, 3 mL of sulfuric acid to 1000 mL of water, allow to cool, and standardize the solution as follows:

Standardization: Weigh accurately about 80 mg of sodium carbonate (standard reagent), previously heated between 500°C and 650°C for 40 to 60 minutes and allowed to cool in a desiccator (silica gel). Dissolve it in 30 mL of water, and titrate the solution with the prepared sulfuric acid to calculate the molarity factor (indicator: 3 drops of methyl red TS). In the indicator method, when the end point is approached, boil the solution carefully, stopper the flask loosely, allow to cool, and continue the titration until the color of the

solution changes to persistent orange to orange-red.

Each mL of 0.05 mol/L sulfuric acid VS= 5.300 mg of Na_2CO_3

(2) Standard Solutions

Borate pH Standard Solution See pH Determination.

Calcium Hydroxide pH Standard Solution See pH Determination.

Carbonate pH Standard Solution See pH Determination.

Oxalate pH Standard Solution See pH Determination.

Phosphate pH Standard Solution See pH Determination.

Phthalate pH Standard Solution See pH Determination.

Standard Arsenic Solution Pipet 10 mL of Standard Arsenic Stock Solution, add 10 mL of dilute sulfuric acid, and add freshly boiled and cooled water to make exactly 1000 mL. Each mL of the solution contains 1 μg of arsenic (III) trioxide (As_2O_3). Prepare before use and preserve in a glass-stoppered bottle.

Standard Arsenic Stock Solution Weigh accurately 0.100 g of finely powdered arsenic (III) trioxide dried at 105°C for 4 hours, and add 5 mL of sodium hydroxide solution (1 in 5) to dissolve. Add dilute sulfuric acid to neutralize, add further 10 mL of dilute sulfuric acid, and add freshly boiled and cooled water to make exactly 1000 mL.

Standard Iron Solution Weigh exactly 86.3 mg of ammonium iron (III) sulfate dodecahydrate, dissolve in 100 mL of water, and add 5 mL of dilute hydrochloric acid and water to make exactly 1000 mL. Each mL of this solution contains 0.01 mg of iron (Fe).

Standard Lead Solution Measure exactly 10 mL of Standard Lead Stock Solution, and add water to make exactly 100 mL. Prepare before use. Each mL of this solution contains 0.01 mg of lead (Pb).

Standard Lead Stock Solution Weigh exactly 159.8 mg of lead (II) nitrate, dissolve in 10 mL of dilute nitric acid, and add water to make exactly 1000 mL. Prepare and store this solution using glass containers, free from soluble lead salts.

Standard Liquids for Calibrating Viscosimeters [JIS, Standard Liquids for Calibrating Viscosimeters (Z8809)]

Standard Lithium Solution for Atomic Absorption Spectrophotometry Weigh exactly 6.107 g of lithium chloride (anhydrous) and dissolve in 0.01 mol/L hydrochloric acid TS to make exactly 1000 mL. Each mL of this solution contains 1.00 mg of lithium (Li).

Standard Vinyl Chloride Solution Transfer ethanol to a 200-mL volumetric flask in a volume of 2 to 3 mL smaller than the marked volume, stopper with a silicone rubber stopper and measure the mass. Inject about 200 mg of liquefied vinyl chloride through the silicone rubber stopper to dissolve in ethanol. Then, measure the weight, determine the increase in mass exactly, and define this value as "a." Add ethanol to make exactly 200 mL through the silicone rubber stopper, shake well to make uniform, and use this solution as the standard vinyl chloride stock solution. Cool the standard vinyl chloride stock solution in a methanol-dry ice bath, transfer 95 mL of cooled ethanol in a 100-mL volumetric flask in the same manner, add 1 mL of the standard stock solution while cooling, and allow to stand to room temperature. Then, add ethanol to make 100 mL, and

use this solution as the vinyl chloride standard solution. The concentration of the standard stock solution is $a/(100 \times 1.0567)$ ppm. Dilute the standard solution with ethanol to prepare standard solutions for calibration curve with a concentration of 0.1 to 10 ppm.

(3) Matching Fluids for Color

Cobaltous Chloride Colorimetric Stock Solution

Weigh 65 g of cobaltous chloride (cobalt (II) chloride hexahydrate), and dissolve in 25 mL of hydrochloric acid and water to make 1000 mL. Pipet 5 mL of this solution into a 250-mL iodine flask. Add 5 mL of hydrogen peroxide TS and 15 mL of a solution of sodium hydroxide (1 in 5), and boil for 10 minutes. Cool, and add 2 g of potassium iodide and 20 mL of diluted sulfuric acid (1 in 4). When the precipitate dissolves, titrate the liberated iodine with 0.1 mol/L sodium thiosulfate VS (indicator: 1 mL of starch TS).

Each mL of 0.1 mol/L sodium thiosulfate VS = 23.793 mg of $\text{CoCl}_2 \cdot 6\text{H}_2\text{O}$

According to the titration value, add diluted hydrochloric acid (1 in 40) to make a solution containing 59.5 mg of cobaltous chloride ($\text{CoCl}_2 \cdot 6\text{H}_2\text{O}$: 237.93) in each mL, and use this solution as the colorimetric stock solution.

Copper Sulfate Colorimetric Stock Solution

Weigh 65 g of copper sulfate (copper (II) sulfate pentahydrate), and dissolve in 25 mL of hydrochloric acid and water to make 1000 mL. Pipet 10 mL of this solution into an iodine flask. Add 4 mL of acetic acid and 3 g of potassium iodide. Titrate the liberated iodine with 0.1 mol/L sodium thiosulfate (indicator: 1 mL of starch TS).

Each mL of 0.1 mol/L sodium thiosulfate VS = 24.968 mg of $\text{CuSO}_4 \cdot 5\text{H}_2\text{O}$

According to the titrated value, add diluted hydrochloric acid (1 in 40) to make a solution containing 62.4 mg of copper sulfate ($\text{CuSO}_4 \cdot 5\text{H}_2\text{O}$: 249.68) in each mL, and use this solution as the colorimetric stock solution.

Ferric Chloride Colorimetric Stock Solution

Weigh 55 g of ferric chloride (iron (III) chloride hexahydrate), and dissolve in 25 mL of hydrochloric acid and add water to make 1000 mL. Measure exactly 10 mL of this solution, transfer to an iodine flask, add 15 mL of water and 3 g of potassium iodide, stopper tightly, and allow to stand in a dark place for 15 minutes. Add 100 mL of water to the mixture, and titrate the liberated iodine with 0.1 mol/L sodium thiosulfate VS (indicator: 1 mL of starch TS).

Each mL of 0.1 mol/L sodium thiosulfate VS = 27.03 mg of $\text{FeCl}_3 \cdot 6\text{H}_2\text{O}$

According to the titrated value, add diluted hydrochloric acid (1 in 40) to make a solution containing 45.0 mg of ferric chloride ($\text{FeCl}_3 \cdot 6\text{H}_2\text{O}$: 270.30) in each mL, and use this solution as the colorimetric stock solution.

(4) Reference Standards, Reagents and Test Solutions (TS)

Acetanilide reference standard for melting point determination [JP Acetanilide reference standard for melting point determination]

Acetic acid 2-methoxyethyl $\text{CH}_3\text{COOCH}_2\text{CH}_2\text{OCH}_3$

Melting point: -65.1°C , Boiling point: 145°C

Acetic acid, dilute Dilute 6 g of acetic acid (100) with water to make 100 mL (1 mol/L).

Acetic acid, glacial See acetic acid (100).

Acetic acid (100) CH_3COOH [K8355, Acetic acid, Special class]

Acetic anhydride $(\text{CH}_3\text{CO})_2\text{O}$ [K8886, Special class]

Acetone CH_3COCH_3 [K8034, Special class]

Acetonitrile CH_3CN [K8032, Special class]

Acetonitrile for liquid chromatography CH_3CN Colorless clear liquid. Mixable with water.

Purity Ultraviolet light absorbing substances: Determine the absorbances at the following wavelengths as directed under Ultraviolet-visible Spectrophotometry, using water as the control: not more than 0.07 at 200 nm, not more than 0.046 at 210 nm, not more than 0.027 at 220 nm, not more than 0.014 at 230 nm and not more than 0.009 at 240 nm.

Acetophenetidine reference standard for melting point determination [JP Acetophenetidine reference standard for melting point determination]

Acetylene See dissolved acetylene.

Acidic stannous chloride TS See tin (II) chloride TS, acidic.

Acidic tin (II) chloride TS See tin (II) chloride TS, acidic.

Acrylic acid reference standard Acrylic acid (Special class). It contains not be less than 99.0% (Acrylic acid, $\text{C}_3\text{H}_4\text{O}_2$:72.06).

Assay: Weigh accurately about 1 g of this substance, add 20 mL of water, mix, and titrate with 1 mol/L of sodium hydroxide VS (indicator: 2 drops of phenolphthalein TS).

Each mL of 1 mol/L sodium hydroxide VS = 72.06 mg $\text{C}_3\text{H}_4\text{O}_2$

Aldehyde-free ethanol See ethanol, aldehyde-free.

Alizarin S See alizarin red S.

Alizarin S TS See alizarin red S TS.

Alizarin red S $\text{C}_{14}\text{H}_7\text{NaO}_7\text{S}$ [K8057, Special class] Range of color change: pH (yellow) 3.7-5.2 (orange).

Alizarin red S TS Dissolve 0.1 g of alizarin red S in water to make 100 mL, and filter.

α -Alumina for thermal analysis $\alpha\text{-Al}_2\text{O}_3$ Prepared for thermal analysis.

Amidosulfuric acid (standard reagent) HOSO_2NH_2 [K8005, Amidosulfuric acid, Standard reagent for volumetric analysis] or [K8587, Special class]

Ammonia copper TS To 0.5 g of cupric carbonate monohydrate add 10 mL of water, triturate, and add 10 mL of ammonia solution (28).

Ammonia TS To 400 mL of ammonia solution (28) add water to make 1000 mL (10%).

Ammonium chloride NH_4Cl [K8116, Special class]

Ammonium chloride TS Dissolve 10.5 g of ammonium chloride in water to make 100 mL (2 mol/L).

Ammonium iron (III) sulfate dodecahydrate $\text{FeNH}_4(\text{SO}_4)_2 \cdot 12\text{H}_2\text{O}$ [K8982, Ammonium iron (III) sulfate dodecahydrate, Special class]

Ammonium peroxodisulfate $(\text{NH}_4)_2\text{S}_2\text{O}_8$ [K8252, Special class]

Ammonium persulfate See ammonium peroxodisulfate.

Ammonium sodium hydrogenphosphate See ammonium sodium hydrogenphosphate tetrahydrate.

Ammonium sodium hydrogenphosphate tetrahydrate $\text{NaNH}_4\text{HPO}_4 \cdot 4\text{H}_2\text{O}$ [K9013, Special class]

Ammonia solution (28) NH_3 [K8085, Ammonia Water, Special class, Specific gravity: about 0.90, Density: 0.908 g/mL, Content: 28–30%]

Ammonium carbonate [K8613, ammonium carbonate, Special class]

Ammonium carbonate TS Dissolve 20 g of ammonium carbonate in 20 mL of ammonia TS and water to make 100 mL.

Ammonium oxalate $(\text{NH}_4)_2\text{C}_2\text{O}_4 \cdot \text{H}_2\text{O}$ [K8521, ammonium oxalate monohydrate, Special class]

Ammonium oxalate TS Dissolve 3.5 g of ammonium oxalate (monohydrate) in water to make 100 mL.

Ammonium sulfate $(\text{NH}_4)_2\text{SO}_4$ [K8960, Special class]

Ammonium thiocyanate NH_4SCN [K9000, Special class]

Ammonium thiocyanate-cobalt nitrate TS See ammonium thiocyanate-cobalt (II) nitrate TS.

Ammonium thiocyanate-cobalt (II) nitrate TS Dissolve 17.4 g of ammonium thiocyanate and 2.8 g of cobalt (II) nitrate hexahydrate in water to make 100 mL.

Ammonium thiocyanate TS Dissolve 8 g of ammonium thiocyanate in water to make 100 mL (1 mol/L).

Anhydrous Ethanol See ethanol (99.5).

Anhydrous sodium carbonate See sodium carbonate, anhydrous.

Anhydrous sodium sulfate See sodium sulfate, anhydrous.

Arsenic (III) trioxide As_2O_3 [K8044, Arsenic (III) trioxide, Special class]

Arsenic Trioxide See arsenic (III) trioxide.

Barium chloride See barium chloride dihydrate.

Barium chloride dehydrate $\text{BaCl}_2 \cdot 2\text{H}_2\text{O}$ [K8155, Special class]

Barium chloride TS Dissolve 12 g of barium chloride dihydrate in water to make 100 mL (0.5 mol/L).

Barium hydroxide See barium hydroxide octahydrate.

Barium hydroxide octahydrate $\text{Ba}(\text{OH})_2 \cdot 8\text{H}_2\text{O}$ [K8577, Special class] Preserve in tightly stoppered bottles.

Benzene C_6H_6 [K8858, Special class]

Benzyl alcohol $\text{C}_6\text{H}_5\text{CH}_2\text{OH}$ Colorless liquid, having a faint, characteristic odor.

Specific gravity: d_{20}^{20} , 1.042 - 1.053, Purity: not less than 97.0%

Blue litmus paper See litmus paper, blue.

Boric acid H_3BO_3 [K8863, Boric acid, Special class]

Bromothymol blue $\text{C}_{27}\text{H}_{28}\text{Br}_2\text{O}_5\text{S}$ [K8842, Special class] Range of color change: pH (yellow) 6.0-7.6 (blue)

Bromothymol blue TS Dissolve 0.1 g of bromothymol blue in 100 mL of dilute ethanol, and filter if necessary.

Bromoforn CHBr_3 (another name: tribromomethane) Colorless liquid. Preserve in a dark, cold place.

Melting point: $7-9^\circ\text{C}$, boiling point: $149-152^\circ\text{C}$, specific gravity: d^{15} 2.89

1-Butanol $\text{CH}_3(\text{CH}_2)_2\text{CH}_2\text{OH}$ [K8810, Special class]

n-Butanol See 1-butanol.

Caffeine reference standard for melting point determination (JP Caffeine reference standard for melting point determination)

Calcium chloride See calcium chloride dihydrate.

Calcium chloride dihydrate $\text{CaCl}_2 \cdot 2\text{H}_2\text{O}$ [K8122, Special class]

Calcium chloride TS Dissolve 7.5 g of calcium chloride dihydrate in water to make 100 mL (0.5 mol/L).

Calcium hydroxide Ca(OH)_2 [K8575, Special class]

Calcium hydroxide for pH determination [K8575, Special class] Calcium hydroxide prepared for pH determination. Use the saturated solution obtained at 23-27°C of which pH is 12.45 at 25°C.

Calcium hydroxide TS To 3 g of calcium hydroxide add 1000 mL of cold distilled water, and occasionally shake the mixture vigorously for 1 hour. Allow to stand, and use the supernatant liquid (0.04 mol/L).

Calcium nitrite See calcium nitrate tetrahydrate.

Calcium nitrate tetrahydrate $\text{Ca(NO}_3)_2 \cdot 4\text{H}_2\text{O}$ [K8549, Special class]

Carbon tetrachloride CCl_4 [K8459, Special class]

Catechol $\text{C}_6\text{H}_4(\text{OH})_2$ White to gray granules or crystals. It is odorless or has a faint, characteristic odor. Melting point: 103°C - 107°C, Purity: not less than 98.0%.

Chloroform CHCl_3 [K8322, Special class]

Cobalt (II) chloride hexahydrate $\text{CoCl}_2 \cdot 6\text{H}_2\text{O}$ [K8129, Special class]

Cobalt (II) nitrate hexahydrate $\text{Co(NO}_3)_2 \cdot 6\text{H}_2\text{O}$ [K8552, Special class]

Cobalt chloride See cobalt (II) chloride hexahydrate.

Cobaltus chloride See cobalt (II) chloride hexahydrate.

Cobaltous nitrate See cobalt (II) nitrate hexahydrate.

Copper (II) sulfate pentahydrate $\text{CuSO}_4 \cdot 5\text{H}_2\text{O}$ [K8983, Special class]

Cupric carbonate See cupric carbonate monohydrate.

Cupric carbonate monohydrate $\text{CuCO}_3 \cdot \text{Cu(OH)}_2 \cdot \text{H}_2\text{O}$ A blue to blue-green powder. It is insoluble in water, and dissolves foamingly in dilute acid. It dissolves in ammonia TS and shows a deep blue color.

Purity

(1) Chloride: Not more than 0.036%.

(2) Sulfate: Not more than 0.120%.

(3) Iron: Dissolve 5.0 g of this substance in excess ammonia TS and filter. Wash the residue with ammonia TS, dissolve in dilute hydrochloric acid, add excess ammonia TS and filter. Wash the residue with ammonia TS, and dry to constant mass: the residue is not more than 10 mg.

Cupric sulfate See copper (II) sulfate pentahydrate.

Dibasic sodium phosphate, anhydrous, for pH determination See disodium hydrogen phosphate for pH determination.

Dibenzylamine $(\text{C}_6\text{H}_5\text{CH}_2)_2\text{NH}$ A colorless or yellowish clear liquid, practically insoluble in water, soluble in alcohol and ethanol. Purity: not less than 98.0%.

Specific gravity: 1.027-1.032.

1,2-Dibromoethane $\text{BrH}_2\text{CCH}_2\text{Br}$ Colorless liquid having a characteristic odor.

Melting point: 9°C - 10°C, Boiling point: 131°C - 132°C, d^0 2.21, d^{20} 2.18

1,3-Dibromopropane $\text{Br(CH}_2)_3\text{Br}$

Diethylene glycol $\text{HO(CH}_2\text{CH}_2\text{O)}_2\text{H}$ Colorless and odorless liquid. Miscible with water and with ethanol (95).

Specific gravity: d_{20}^{20} 1.118-1.120

Diethyl ether $\text{C}_2\text{H}_5\text{OC}_2\text{H}_5$ [K8103, Special class]

Dilute acetic acid See acetic acid, dilute.

Dilute ethanol See ethanol, dilute.

Dilute hydrochloric acid See hydrochloric acid, dilute.

Dilute methylene blue TS See methylene blue TS, dilute.

Dilute nitric acid See nitric acid, dilute.

Dilute sulfuric acid See sulfuric acid, dilute.

N,N-Dimethylacetamide $\text{CH}_3\text{CON}(\text{CH}_3)_2$ A clear, colorless liquid.

Boiling point: 163-165°C, Specific gravity: 0.938-0.945, Water content: not more than 0.2% (0.1 g, Coulometric titration).

Purity: Perform the test with 3 μL of this substance as directed under Gas Chromatography according to the following conditions, and measure the area of each peak using automatic integration. Calculate the amount of N,N-Dimethylacetamide by the area percentage method: not less than 98.0%.

Operating conditions

Detector: Hydrogen flame-ionization detector

Column: A fused silica column, 0.25 mm in the inside diameter and 30 m in length, coated with polyethylene glycol 20M for gas chromatography 0.5 μm in thickness

Column temperature: The sample is injected at a constant temperature of about 70°C, keep this temperature for 1 minute, then raise to 200°C in a rate of 10°C per minute, and keep 200°C for 3 minutes.

Carrier gas: Helium

Flow rate (linear velocity): About 30 cm/sec

Time span of measurement: About 2 times as long as the retention time of N, N-dimethylacetamide.

p-Dimethylaminobenzaldehyde See 4-dimethylaminobenzaldehyde.

4-Dimethylaminobenzaldehyde $(\text{CH}_3)_2\text{NC}_6\text{H}_4\text{CHO}$ [K8496, p-Dimethylaminobenzaldehyde, Special class]

N,N-Dimethylformamide $\text{HCON}(\text{CH}_3)_2$ [K8500, Special class]

Dimethylformamide See N,N-dimethylformamide.

Dimethylsulfoxide $(\text{CH}_3)_2\text{SO}$ [K9702, Special class]

Dimethylsulfoxide for ultraviolet-visible spectrophotometry Colorless crystals or clear colorless liquid, having a characteristic odor.

It is highly hygroscopic.

Congealing point: Not less than 18.3°C

Purity: Read absorbance of this substance, immediately after saturating with nitrogen, using water as the blank as directed under Ultraviolet-visible Spectrophotometry: its value is not more than 0.20 at 270 nm, not more than 0.09 at 275 nm, not more than 0.06 at 280 nm, and not more than 0.015 at 300 nm. It exhibits no characteristic absorption between 260 nm and 350 nm.

Water content: Not more than 0.1.

Diphenylmethane diisocyanate $\text{C}_{15}\text{H}_{10}\text{O}_2\text{N}_2$ White to pale yellow solid. Soluble in benzene, toluene, acetone, and ether.

Specific gravity: d_4^{50} 1.19, Boiling point: 190°C (665 Pa)

Disodium hydrogen phosphate dodecahydrate $\text{Na}_2\text{HPO}_4 \cdot 12\text{H}_2\text{O}$ [K9019, Disodium hydrogen phosphate dodecahydrate, Special class]

Disodium hydrogen phosphate for pH determination Na_2HPO_4 [K9020, Disodium hydrogen phosphate, for pH standard solution]

Dissolved acetylene C_2H_2 [K1902]

Epichlorohydrin C_3H_5ClO Colorless liquid, having a pungent odor similar to chloroform, specific gravity of 1.1801, and boiling point of 117°C. Purity: not less than 99%.

Ethanol See ethanol (95).

Ethanol, aldehyde-free Transfer 1000 mL of ethanol (95) to a glass-stoppered bottle, add the solution prepared by dissolving 2.5 g of lead (II) acetate trihydrate in 5 mL of water, and mix thoroughly. In a separate container, dissolve 5 g of potassium hydroxide in 25 mL of warm ethanol (95), cool, and add this solution gently, without stirring, to the first solution. After 1 hour, shake this mixture vigorously, allow to stand overnight, decant the supernatant liquid, and distil the ethanol.

Ethanol, anhydrous See ethanol (99.5).

Ethanol, dilute To 1 volume of ethanol (95) add 1 volume of water. C_2H_5OH Content: 47.45 to 50.00 vol%

Ethanol (95) C_2H_5OH [K8102, Special class]

Ethanol (99.5) C_2H_5OH [K8101, Special class]

Ether See diethyl ether.

Ethyl iodine See iodoethane.

Ethylene bromide See 1,2-dibromoethane.

Ferric ammonium sulfate See ammonium iron (III) sulfate dodecahydrate.

Ferric chloride See iron (III) chloride hexahydrate.

Fluorescence Reference Standard 1 Weigh exactly 7 mg of fluorescent brightener (Fluorescent-24) in a brown volumetric flask, add water to make exactly 500 mL, and store protected from light.

To 5 mL of this solution, add 0.1 g of sodium chloride and water to make 50 mL, immerse a filter paper (8 cm × 15 cm) into the resultant solution for 1 hour with occasional inverting and air-dry it on a filter paper.

Fluorescence Reference Standard 2 Weigh exactly 7 mg of fluorescent brightener (Fluorescent-351) in a brown volumetric flask, add water to make exactly 500 mL, and store protected from light. To 0.35 mL of this solution, add 0.1 g of sodium chloride and water to make 50 mL, immerse a filter paper (8 cm × 15 cm) into the resultant solution for 1 hour with occasional inverting and air-dry it on a filter paper.

Fluorescent-24 $C_{40}H_{44}N_{12}Na_4O_{16}S_4$ Delayed-staining stilbene fluorescent brightener. Color index name: C.I. Fluorescent brightener-24 (C.I. No. 40650), Chemical name: Tetrasodium 4,4'-bis[[4-[bis(2-hydroxyethyl)amino]-6-[(3-sulphonato-phenyl)amino]-1,3,5-triazine-2-yl]amino]stilbene-2,2'-disulfonate (CAS No. 12224-02-1)

Fluorescent-351 $C_{28}H_{20}Na_2O_6S_2$ Stilbene fluorescent brightener Color index name: C.I. Fluorescent brightener-351 (FWA-5)(C.I.No.482200), Chemical name: Disodium 4,4'-Bis(2-sulfonatostyryl)biphenyl (CAS No. 27344-41-8)

Gauze Use medical gauze conforming to the requirements of Notification No. 0630001 of Secretary-General of Pharmaceutical and Food Safety Bureau, the MHLW dated June 30, 2005.

Glycerin $C_3H_8O_3$ [K8295, Special class] or [Concentrated Glycerin (JP monograph)]

Helium He, not less than 99.995 vol%

Heptane $CH_3(CH_2)_5CH_3$ [K9701, Special class]

n-Heptane See heptane.

Hexane for ultraviolet-visible spectrophotometry [K8848, Special class] When determining the absorbance of hexane as directed under Ultraviolet-visible Spectrophotometry, using water as the blank: not more than 0.10 at 220 nm and not more than 0.02 at 260 nm. It exhibits no absorption between 260 nm and 350 nm.

n-Hexane for ultraviolet-visible spectrophotometry See hexane for ultraviolet-visible spectrophotometry.

Hydrochloric acid HCl [K8180, Special class]

Hydrochloric acid, dilute Dilute 23.6 mL of hydrochloric acid with water to make 100 mL (10%).

0.1 mol/L Hydrochloric acid TS Dilute 100 mL of hydrochloric acid with water to make 1000 mL.

1 mol/L Hydrochloric acid TS Dilute 90 mL of hydrochloric acid with water to make 1000 mL.

Hydrogen peroxide (30) H₂O₂ [K8230, Hydrogen peroxide, Special class, Concentration: 30.0- 35.5%]

Hydrogen peroxide TS Dilute 1 volume of hydrogen peroxide (30) with 9 volumes of water. Prepare before use (3%).

Hydrogen peroxide water, strong See hydrogen peroxide (30).

Hydrogen sulfide H₂S Colorless, poisonous gas, heavier than air. It dissolves in water. Prepare by treating iron (II) sulfide with dilute sulfuric acid or dilute hydrochloric acid. Other sulfides yielding hydrogen sulfide with dilute acids may be used.

Hydroxylamine hydrochloride See hydroxylammonium chloride.

Hydroxylammonium chloride NH₂OH·HCl [K8201, Special class]

Hydroxylammonium hydrochloride See hydroxylammonium chloride.

Indium for thermal analysis Prepared for thermal analysis. Content: not less than 99.99%.

Iodine I [K8920, Iodine, Special class]

Iodine solution See iodine TS (0.05 mol/L).

Iodine TS Dissolve 14 g of iodine in 100 mL of a solution of potassium iodide (2 in 5), add 1 mL of dilute hydrochloric acid, and dilute with water to make 1000 mL (0.05 mol/L).

Storage: Preserve in light-resistant containers.

Iodoethane C₂H₅I A colorless to a dark-brown, clear liquid, having diethyl ether-like odor. Distilling range 71.0-72.5°C, not less than 94 vol%.

Iron (III) chloride hexahydrate FeCl₃·6H₂O [K8142, Special class]

Iron (II) sulfide FeS [K8948, for hydrogen sulfide development]

Isopropanol See 2-propanol.

Isopropyl alcohol See 2-propanol.

Isophorone diisocyanate C₁₂H₁₈N₂O₂ Colorless viscous liquid.

Isotonic sodium chloride solution [Isotonic Sodium Chloride Solution (JP monograph)]

Lead acetate See lead (II) acetate trihydrate.

Lead (II) acetate trihydrate Pb(CH₃COO)₂·3H₂O [K8374, Lead (II) acetate trihydrate, Special class]

Lead (II) acetate TS To 9.5 g of lead (II) acetate trihydrate add freshly boiled and cooled water to make 100 mL (0.25 mol/L). Preserve in tightly stoppered bottles.

Lead monoxide See lead (II) oxide.

Lead nitrate See lead (II) nitrate.

Lead (II) nitrate Pb(NO₃)₂ [K8563, Special class]

Lead (II) oxide PbO [K8090, Special class]

Lithium chloride LiCl White crystals or masses.

Identification: Perform the test as directed under Flame Coloration Test with this substance: a persistent red color develops.

Lithium chloride, anhydrous See lithium chloride.

Litmus paper, blue [K9071, Litmus paper, Blue litmus paper]

Litmus paper, red [K9071, Litmus paper, Red litmus paper]

Magnesium nitrate See magnesium nitrate hexahydrate.

Magnesium nitrate hexahydrate $\text{Mg}(\text{NO}_3)_2 \cdot 6\text{H}_2\text{O}$ [K8567, Special class]

Magnesium sulfate See magnesium sulfate heptahydrate.

Magnesium sulfate heptahydrate $\text{MgSO}_4 \cdot 7\text{H}_2\text{O}$ [K8995, Special class]

Magnesium sulfate TS Dissolve 12 g of magnesium sulfate heptahydrate in water to make 100 mL (0.5 mol/L).

Methanol CH_3OH [K8891, Special class]

Methylene blue $\text{C}_{16}\text{H}_{18}\text{ClN}_3\text{S} \cdot 3\text{H}_2\text{O}$ [K 8897, Special class]

Methylene blue TS Dissolve 0.1g of methylene blue in 100 mL of ethanol, and filter if necessary.

Methylene blue TS, dilute Dilute 1 mL of methylene blue TS with water to make 100 mL.

Methylene iodide CH_2I_2 (another name: Diiodomethane) Yellow liquid.

Melting point: 6°C, boiling point: 181°C, specific gravity: d_{15}^{15} 3.3326

Methyl glycol acetate See acetic acid 2-methoxyethyl.

Methyl orange $\text{C}_{14}\text{H}_{14}\text{N}_3\text{NaO}_3\text{S}$ [K8893, Special class] Range of color change: pH (red) 3.1-4.4 (orange-yellow).

Methyl orange TS Dissolve 0.1 g of methyl orange in 100 mL of water, and filter if necessary.

Methyl red $\text{C}_{15}\text{H}_{15}\text{N}_3\text{O}_2$ [K8896, Special class] Range of color change: pH (red) 4.2-6.2 (yellow).

Methyl red TS Dissolve 0.1 g of methyl red in 100 mL of ethanol (95), and filter if necessary.

Nitric acid HNO_3 [K8541, Special class, Concentration: 69 - 70%, Density: about 1.42 g/mL]

Nitric acid, dilute Dilute 10.5 mL of nitric acid with water to make 100 mL (10%).

Nitrogen N_2 [Nitrogen (JP monograph)]

Octadecylsilanized silica gel for liquid chromatography Prepared for liquid chromatography

n-Octane C_8H_{18}

Specific gravity: d_4^{20} 0.700 – 0.705

Purity: Perform the test with 2 μL of this substance as directed under Gas Chromatography according to the conditions in the Assay under Hypromellose. Measure each peak area by the automatic integration method, and calculate the amount of n-octane by the area percentage method: not less than 99.0%.

Perchloroethylene [K 1521, Tetrachloroethylene]

Phenolphthalein $\text{C}_{20}\text{H}_{14}\text{O}_4$ [K8799, Special class] Range of color change: pH (colorless) 8.3-10.0 (red)

Phenolphthalein TS Dissolve 1 g of phenolphthalein in 100 mL of ethanol (95).

Phloroglucin See phloroglucinol dehydrate.

Phloroglucinol dehydrate $\text{C}_6\text{H}_3(\text{OH})_3 \cdot 2\text{H}_2\text{O}$ White to pale yellow crystals or crystalline powder. Melting point: 215-219°C (after drying), Loss on drying: 18.0-24.0% (1 g, 105°C, 1 hour)

Phosphorus (V) oxide P_2O_5 [K8342, Phosphorus (V) oxide, Special class]

Polyethylene glycol 20M for gas chromatography Prepared for gas chromatography.

Potassium Bromide KBr [K8506, Special class]

Potassium bromide for infrared spectrophotometry Crush homocrystals of potassium bromide or potassium bromide, collect a powder passed through a No. 200 (75 μm) sieve, and dry at 120°C for 10 hours or at 500°C for 5 hours. Prepare tablets with this powder, and determine the infrared absorption spectrum: any abnormal absorption does not appear.

Potassium bromate KBrO_3 [K8530, Special class]

Potassium bromate-potassium bromide TS Dissolve 1.4 g of potassium bromate and 8.1 g of potassium bromide in water to make 100 mL.

Potassium chloride KCl [K8121, Special class]

Potassium chromate K_2CrO_4 [K8312, potassium chromate, Special class]

Potassium chromate TS Dissolve 10 g of potassium chromate in water to make 100 mL.

Potassium dihydrogen phosphate KH_2PO_4 [K9007, Potassium dihydrogen phosphate, Special class]

Potassium dihydrogen phosphate for pH determination KH_2PO_4 [K9007, Potassium dihydrogen

Potassium hydrogen phthalate for pH determination $\text{C}_6\text{H}_4(\text{COOK})(\text{COOH})$ [K8809, for pH standard solution]

Potassium hydroxide KOH [K8574, Special class]

Potassium hydroxide-ethanol TS Dissolve 10 g of potassium hydroxide in ethanol (95) to make 100 mL. Prepare before use.

Potassium iodide KI [K8913, Potassium iodide, Special class]

Potassium iodate (standard reagent) KIO_3 [K8005, Potassium iodate, Standard reagent for volumetric analysis]

Potassium iodide TS Dissolve 16.5 g of potassium iodide in water to make 100 mL. Preserve in light-resistant containers. Prepare before use (1 mol/L).

phosphate, for pH standard solution]

Potassium Permanganate KMnO_4 [K8247, Special class]

Potassium tetraoxalate for pH determination See potassium trihydrogen dioxalate dihydrate for pH determination.

Potassium trihydrogen dioxalate dihydrate for pH determination $\text{KH}_3(\text{C}_2\text{O}_4)_2 \cdot 2\text{H}_2\text{O}$ [K8474, Potassium trihydrogen dioxalate dihydrate for pH determination]

2-Propanol $(\text{CH}_3)_2\text{CHOH}$ [K8839, Special class]

Pyridine $\text{C}_5\text{H}_5\text{N}$ [K8777, Special class]

Red litmus paper See litmus paper, red.

Silica gel An amorphous, partly hydrated silicic acid occurring in glassy granules of various sizes. When used as a desiccant, it is frequently coated with a substance that changes color when the capacity to absorb water is exhausted. Such colored products may be regenerated by being heated at 110°C until the gel assumes the original color.

Loss on ignition: Not more than 6% (2 g, 950 \pm 50°C)

Water absorption: Not less than 31%. Weigh accurately about 10 g of this substance, and allow to stand for 24 hours in a closed container in which the atmosphere is maintained at 80% relative humidity with sulfuric acid having a specific gravity of 1.19. Weigh again, and calculate the increase in mass.

Siliceous earth [K8330, Siliceous earth, First class]

Siliceous earth for gas chromatography Prepared for gas chromatography.

Silicone oil Colorless clear liquid, having no odor. Viscosity 50-100 mm²/s

Silver diethyldithiocarbamate See silver N, N-diethyldithiocarbamate.

Silver N,N-diethyldithiocarbamate C₅H₁₀AgNS₂ [K9512, Special class]

Silver Nitrate AgNO₃ [K8550, Special class]

Silver nitrate TS Dissolve 17.5 g of silver nitrate in water to make 1000 mL (0.1 mol/L). Preserve in light-resistant containers.

Soda lime [K8603, for carbon dioxide absorption]

Sodium acetate See sodium acetate trihydrate.

Sodium acetate trihydrate CH₃COONa·3H₂O [K8371, Special class]

Sodium borate for pH determination See sodium tetraborate decahydrate for pH determination.

Sodium bromide NaBr [K8514, Special class]

Sodium carbonate, anhydrous Na₂CO₃ [K8625, Sodium carbonate, Special class]

Sodium carbonate for pH determination Na₂CO₃ [K8625, for pH standard solution]

Sodium carbonate (standard reagent) Na₂CO₃ [K8005, Sodium carbonate, Standard reagent for volumetric analysis]

Sodium chloride NaCl [K8150, Special class]

Sodium hydrogen carbonate for pH determination NaHCO₃ [K8622, for pH standard solution]

Sodium hydroxide NaOH [K8576, Special class]

Sodium hydroxide TS Dissolve 4.3 g of sodium hydroxide in water to make 100 mL (1 mol/L). Preserve in polyethylene bottles.

Sodium oxalate (standard reagent) C₂O₄Na₂ [K8005, Sodium oxalate, Standard reagent for volumetric analysis] or [K8528, Sodium oxalate, Special class]

Sodium sulfate, anhydrous Na₂SO₄ [K8987, Sodium sulfate, Special class]

Sodium sulfide enneahydrate Na₂S·9H₂O [K8949, Special class]

Sodium sulfide TS Dissolve 5 g of sodium sulfide enneahydrate in a mixture of 10 mL of water and 30 mL of glycerin. Or dissolve 5 g of sodium hydroxide in a mixture of 30 mL of water and 90 mL of glycerin, saturate a half volume of this solution with hydrogen sulfide, while cooling, and mix with the remaining half. Preserve in well-filled, light-resistant bottles. Use within 3 months.

Sodium tetraborate decahydrate for pH determination [K8866, Sodium tetraborate decahydrate for pH standard solution]

Sodium thiosulfate See sodium thiosulfate pentahydrate.

Sodium thiosulfate pentahydrate Na₂S₂O₃·5H₂O [K8637, Special class]

Stannous chloride See tin (II) chloride dihydrate.

Stannous chloride TS, acidic See tin (II) chloride TS, acidic.

Starch [K8658, Starch, Special class]

Starch TS Triturate 1 g of starch with 10 mL of cold water, and pour the mixture slowly, with constant stirring, into 200 mL of boiling water. Boil the mixture until a thin, translucent fluid is obtained. Allow to settle, and use the supernatant liquid. Prepare before use.

Strong ammonia water See ammonia solution (28).

Strong ammonium water See ammonia solution (28).

Strong hydrogen peroxide water See hydrogen peroxide (30).

Styrene C_8H_8 Clear and colorless liquid.

Specific gravity: 0.902-0.910.

Purity Perform the test with 1 μ L of this substance as directed under Gas Chromatography according to the following conditions. Measure each peak area by the automatic integration method and calculate the amount of styrene by the area percentage method: it shows the purity of not less than 99%.

Operating conditions

Detector: Thermal conductivity detector

Column: A glass column about 3 mm in inside diameter and about 2 m in length, packed with siliceous earth for gas chromatography (180 to 250 μ m) coated with polyethylene glycol 20 M for gas chromatography in 10%

Column temperature: A constant temperature of about 100°C

Temperature of sample vaporization chamber: A constant temperature of about 150°C

Carrier gas: Helium

Flow rate: Adjust the flow rate so that the retention time of styrene is about 10 minutes.

Time span of measurement: About twice as long as the retention time of styrene

Sulfamic acid (standard reagent) See amidosulfuric acid (standard reagent).

Sulfanilamide reference standard for melting point determination (JP Sulfanilamide reference standard for melting point determination)

Sulfapyridine reference standard for melting point determination (JP Sulfapyridine reference standard for melting point determination)

Sulfuric acid H_2SO_4 [K8951, Special class]

Sulfuric acid (94.5-95.5%) See sulfuric acid for readily carbonizable substances.

Sulfuric acid, dilute Cautiously add 5.7 mL of sulfuric acid to 10 mL of water, cool, and dilute with water to make 100 mL (10%).

Sulfuric acid for readily carbonizable substances To sulfuric acid, the content of which has previously been determined by the following method, add water cautiously, and adjust the final concentration to 94.5% to 95.5% of sulfuric acid (H_2SO_4). When the concentration is changed owing to absorption of water during storage, prepare freshly.

Assay: Weigh accurately about 2 g of sulfuric acid in a glass-stoppered flask rapidly, add 30 mL of water, cool, and titrate the solution with 1 mol/L sodium hydroxide VS (indicator: 2 to 3 drops of bromothymol blue TS).

Each mL of 1 mol/L sodium hydroxide VS = 49.04 mg H_2SO_4

Tetrahydrofuran $CH_2(CH_2)_2CH_2O$ [K9705, Special class]

Tetrahydrofuran for gas chromatography Use tetrahydrofuran prepared by distilling with iron (II) sulfate heptahydrate. Preserve in containers, in which the air has been displaced by nitrogen, in a dark, cold place.

Tin (II) chloride dihydrate $SnCl_2 \cdot 2H_2O$ [K8136, Special class]

Tin (II) chloride TS, acidic Dissolve 8 g of Tin (II) chloride dihydrate in 500 mL of hydrochloric acid.

Preserve in glass-stoppered bottles. Use within 3 months.

Tin for thermal analysis [K8580, Tin, Special class, Content: not less than 99.99%]

Toluene $C_6H_5CH_3$ [K8680, Special class]

Vanillin reference standard for melting point determination (JP Vanillin reference standard for melting point determination)

Vinyl chloride C_2H_3Cl Colorless gas. Boiling point: $-14^{\circ}C$, Melting point: $-160^{\circ}C$

Xylene $C_6H_4(CH_3)_2$ [K8271, First class]

Zinc for arsenic analysis Zn [K 8012, for arsenic analysis] Use granules of about 800 μm .

Zinc, arsenic-free See zinc for arsenic analysis.

Zinc chloride $ZnCl_2$ [K8111, Special class]

(5) Measuring Instruments and Appliances

Balances and weights

- (1) Chemical balances Use balances readable to the extent of 0.1 mg.
- (2) Semimicrobalances Use balances readable to the extent of 0.01 mg.
- (3) Microbalances Use balances readable to the extent of 0.001 mg.
- (4) Weights Use calibrated weights.

Filter paper

Use the filter paper conforming to the following specifications. A filter paper without specification means that for qualitative analysis. Store protected from contamination with gas, etc.

Filter paper for qualitative analysis

Use the filter papers conforming to the specifications for filter papers for qualitative analysis (for chemical analysis) provided in P3801 of the JIS.

Filter papers for quantitative analysis

Use the filter papers conforming to the specifications for filter papers for quantitative analysis (for chemical analysis) provided in P3801 of the JIS.

Gas flowmeters for gas chromatography

Use the flowmeter provided in K1518 of the JIS.

Micro-syringes for gas chromatography and liquid chromatography

Use commercial micro-syringes for gas chromatography.

Nessler tubes

Use colorless, glass-stoppered cylinders 1.0 to 1.5 mm in thickness, made of hard glass as shown in the figure below. The difference of the height of the graduation line of 50 mL from the bottom among cylinders does not exceed 2 mm.



(The figures are in mm.)

Sieves

Use the sieves provided in Z8801 of the JIS.

Use the sieve number or nominal size (μm) as the designation.

Sieve number	Nominal size (μm)	Specification of sieves				
		Sieve opening (mm)			Wire (mm)	
		Size (mm)	Permissible variation%		Diameter	Permissible variation%
			Average	Maximum		
3.5	5600	5.60	± 0.14	0.42	1.60	± 0.040
4	4750	4.75	± 0.118	0.41	1.60	± 0.040
4.7	4000	4.00	± 0.100	0.37	1.40	± 0.040
5.5	3350	3.35	± 0.100	0.32	1.25	± 0.030
6.5	2800	2.80	± 0.084	0.28	1.12	± 0.030
7.5	2360	2.36	± 0.070	0.24	1.00	± 0.030
8.6	2000	2.00	± 0.060	0.20	0.90	± 0.030
10	1700	1.70	± 0.051	0.17	0.80	± 0.025
12	1400	1.40	± 0.042	0.14	0.71	± 0.025
14	1180	1.18	± 0.035	0.14	0.63	± 0.025
16	1000	1.00	± 0.030	0.14	0.56	± 0.025
18	850	0.85	± 0.029	0.127	0.50	± 0.025
22	710	0.71	± 0.025	0.112	0.45	± 0.025
26	600	0.60	± 0.021	0.101	0.40	± 0.020
30	500	0.50	± 0.018	0.089	0.315	± 0.020
36	425	0.425	± 0.016	0.081	0.280	± 0.020
42	355	0.355	± 0.013	0.072	0.224	± 0.020
50	300	0.300	± 0.012	0.065	0.200	± 0.015
60	250	0.250	± 0.0099	0.058	0.160	± 0.015
70	212	0.212	± 0.0087	0.052	0.140	± 0.015
83	180	0.180	± 0.0076	0.047	0.125	± 0.015
100	150	0.150	± 0.0066	0.043	0.100	± 0.015
119	125	0.125	± 0.0058	0.038	0.090	± 0.015
140	106	0.106	± 0.0052	0.035	0.071	± 0.010
166	90	0.090	± 0.0046	0.032	0.063	± 0.007
200	75	0.075	± 0.0041	0.029	0.050	± 0.007
235	63	0.063	± 0.0037	0.026	0.045	± 0.005
282	53	0.053	± 0.0034	0.024	0.036	± 0.005
330	45	0.045	± 0.0031	0.022	0.032	± 0.005
391	38	0.038	± 0.0029	0.020	0.030	± 0.005

Sintered glass filters

Use the sintered glass filter provided in R3503 of the JIS.

Thermometers

Ordinarily, use rod thermometers with an immersion line or total immersion mercury rod thermometers, calibrated under the JIS. Use the rod thermometers with the immersion line, shown in the table below, for the purpose of determining specific gravity, melting point, congealing point, boiling point, and the distilling range.

	No.1	No.2	No.3	No.4	No.5	No.6
Liquid	Mercury	Mercury	Mercury	Mercury	Mercury	Mercury
Gas filled above liquid	Nitrogen	Nitrogen	Nitrogen	Nitrogen	Nitrogen	Nitrogen
Temperature range	-17-50°C	40-100°C	90-150°C	140-200°C	190-250°C	240-320°C
Minimum graduation	0.2°C	0.2°C	0.2°C	0.2°C	0.2°C	0.2°C
Longer graduation lines at	each 1°C	each 1°C	each 1°C	each 1°C	each 1°C	each 1°C
Graduation numbered at	each 2°C	each 2°C	each 2°C	each 2°C	each 2°C	each 2°C
Total length (mm)	280-300	280-300	280-300	280-300	280-300	280-300
Stem diameter (mm)	6.0±0.1	6.0±0.1	6.0±0.1	6.0±0.1	6.0±0.1	6.0±0.1
Bulb length (mm)	12-15	12-15	12-15	12-15	12-15	12-15
Distance from bottom of bulb to graduation at the lowest temperature (mm)	75-90	75-90	75-90	75-90	75-90	75-90
Distance from top of thermometer to graduation at the highest temperature (mm)	35-50	35-50	35-50	35-50	35-50	35-50
Distance from bottom of bulb to immersion line(mm)	60	60	60	60	60	60
Form of top of thermometer	loop	loop	loop	loop	loop	loop
Maximum scale error at any point	0.2°C	0.2°C	0.2°C	0.2°C	0.2°C	0.2°C

For the No. 1, No. 2 and No. 6 thermometers, the quality of the glass shall be of Jena 16III or higher, and for No. 4, No. 5 and No. 6, Jena 59III or higher.

Thermometers for low pour-point

Use the thermometers provided in B7410 of the JIS.

Thermometers for high pour-point

Use the thermometers provided in B7410 of the JIS.

Volumetric measures for chemical use

Use volumetric flasks, transfer pipets, burettes and measuring cylinders provided in R3505 of the JIS.

<3. Monographs>

Part 1 - Materials

Ionomer Resin

Definition

Ionomer Resin is a copolymer resin, partially cross-linked with sodium hydroxide or zinc oxide, obtained by copolymerizing ethylene and acrylic acid or ethylene and methacrylic acid.

Description

It occurs as translucent powder or granules, and it is practically odorless.

Identification

Determine the infrared absorption spectrum of this substance as directed in the film method under Infrared Spectrophotometry: it exhibits absorption at the wave numbers of about 3440 cm^{-1} , between 3000 cm^{-1} and 2900 cm^{-1} , 1378 cm^{-1} , 1190 cm^{-1} , 1140 cm^{-1} and 720 cm^{-1} .

Specific gravity: 0.93-0.99

Melting point: 80-100°C

Purity

(1) Clarity and color of solution

Dissolve 1 g of this substance in 50 mL of xylene by heating: the solution is colorless and clear.

(2) Heavy metals: Not more than 20 ppm (Method 2)

(3) Arsenic: Not more than 2 ppm (Method 2)

Residue on ignition: Not more than 0.1% (5.0 g, Method 1)

Alkyl Acrylate-Vinyl Acetate Copolymer Emulsion (2)

Definition

Alkyl Acrylate-Vinyl Acetate Copolymer Emulsion (2) is a copolymer emulsion mainly consisting of more than one component in alkyl acrylate ($C_1 - C_4$, C_8 and C_{12}) and alkyl methacrylate ($C_1 - C_4$, C_8 and C_{12}), and vinyl acetate.

Description

It is a milky white liquid and it has a faint, characteristic odor.

Identification

Determine the infrared absorption spectrum of this substance as directed in the film method under Infrared Spectrophotometry: it exhibits absorption at the wave numbers of about between 2940 cm^{-1} and 2900 cm^{-1} , 1730 cm^{-1} (ester), 1450 cm^{-1} , 1240 cm^{-1} , 1020 cm^{-1} and 720 cm^{-1} .

pH: 6.0-8.5

Purity

(1) Heavy metals: Not more than 20 ppm (Method 2)

(2) Arsenic: Not more than 2 ppm (Method 2)

Partial Potassium Salt of Polyacrylic Acid

Definition

Partial Potassium Salt of Polyacrylic Acid is a water-absorbing resin consisting of slightly cross-linked partial

potassium salt of polyacrylic acid as a principal component.

Description

- (1) It occurs as a white powder and it is practically odorless.
- (2) It swells with water but is practically insoluble in water.
- (3) Melting point: Not less than 200°C (with decomposition)

Identification

- (1) To 1.0 g of this substance, add 100 mL of water, stir and allow to stand for 10 minutes: the solution becomes gelatinous.
- (2) To 10 g of the gelatinous substance (1), add 1 mL of calcium chloride TS and shake: a white precipitate is produced.
- (3) To 10 g of the gelatinous substance (1), add 1 mL of magnesium sulfate TS and shake: a white precipitate is produced.
- (4) To 10 g of the gelatinous substance (1), add 1 mL of cobalt chloride solution (1 in 25), add 2 or 3 drops of ammonium chloride TS and shake: a light red precipitate is produced. Dry the precipitate: a purple color develops.
- (5) Ignite this substance to incinerate and perform the test with the residue as directed under Flame Coloration Test: it responds to the Qualitative Test for potassium.

Purity

- (1) Coloring matter

Immerse this substance in ethanol not less than 10 times the mass of this substance, stir for 10 minutes and filter: the filtrate is a colorless clear liquid.

- (2) Acidity or alkalinity

To 1.0 g of this substance, add 500 mL of freshly boiled and cooled water and allow to cool. To 25 mL of this solution, add 3 drops of phenolphthalein TS: no red color develops. Separately, to 25 mL of the solution, add 1 drop of methyl orange TS: a yellow color develops.

- (3) Fluorescence

Irradiate this substance with ultraviolet rays (main wavelength: 365 nm) in a dark place: it shows no marked fluorescence.

- (4) Heavy metals: Not more than 20 ppm (Method 2)

- (5) Acrylic acid

Method 1

To 5.0 g of this substance, add exactly 10 mL of methanol, shake for 4 hours, allow to stand and use the supernatant liquid as the sample solution. Separately, take 0.010 g of the acrylic acid reference standard, dissolve in methanol to make exactly 200 mL and use the solution as the standard solution. Perform the test with 5 µL each of the sample solution and standard solution as directed under Gas Chromatography. Determine the peak heights, H_t and H_s , of acrylic acid of respective solutions: H_t is not higher than H_s .

Method 2

To 1.0 g of this substance, add 250 mL of saline, stir for 2 hours, filter, and use the resultant solution as

the sample solution. Separately, take 0.20 g of acrylic acid reference standard, dissolve in saline to make exactly 100 mL. To 1 mL of the solution, add saline to make exactly 250 mL and use as the standard solution. Perform the test with 20 μ L each of the sample solution and the standard solution as directed under Liquid Chromatography. Determine the peak heights, Ht and Hs, of acrylic acid of respective solutions: Ht is not higher than Hs.

Loss on drying: Not more than 15% (2.0 g, 105°C, 3 hours)

Residue on ignition: Not more than 76% (Method 1)

Absorbency

Take 1.0 g of this substance in a nylon woven fabric (10 cm in width, 20 cm in length, 255 mesh), immerse in 1000 mL of saline for 1 hour, allow to stand for 10 minutes, remove excessive water and determine absorbency: it absorbs not less than 10 times its weight.

Note) Identify acrylic acid according to Method 1 or Method 2.

Partial Sodium Salt of Polyacrylic Acid

Definition

Partial Sodium Salt of Polyacrylic Acid is a water-absorbing resin consisting of slightly cross-linked partial sodium salt of polyacrylic acid as a principal component.

Description

- (1) It occurs as a white powder and it is practically odorless.
- (2) It swells with water but is practically insoluble in water.
- (3) Melting point: Not less than 200°C (with decomposition)

Identification

- (1) To 1.0 g of this substance, add 100 mL of water, stir and allow to stand for 10 minutes: the solution becomes gelatinous.
- (2) To 10 g of the gelatinous substance (1), add 1 mL of calcium chloride TS and shake: a white precipitate is produced.
- (3) To 10 g of the gelatinous substance (1), add 1 mL of magnesium sulfate TS and shake: a white precipitate is produced.
- (4) To 10 g of the gelatinous substance (1), add 1 mL of cobalt chloride solution (1 in 25), add 2 or 3 drops of ammonium chloride TS and shake: a light red precipitate is produced. Dry the precipitate: a purple color develops.
- (5) Ignite this substance to incinerate and perform the test with the residue as directed under the Flame Coloration Test: it responds to the Qualitative Test for sodium.

Purity

- (1) Coloring matter

Immerse this substance in ethanol not less than 10 times the mass of this substance, stir for 10 minutes and filter: the filtrate is a colorless clear liquid.

- (2) Acidity or alkalinity

To 1.0 g of this substance, add 500 mL of freshly boiled and cooled water and allow to cool. To 25 mL of this solution, add 3 drops of phenolphthalein TS: no red color develops. Separately, to 25 mL of the solution, add 1 drop of methyl orange TS: a yellow color develops.

(3) Fluorescence

Irradiate this substance with ultraviolet rays (main wavelength: 365 nm) in a dark place: it shows no marked fluorescence.

(4) Heavy metals: Not more than 20 ppm (Method 2)

(5) Acrylic acid

Method 1

To 5.0 g of this substance, add exactly 10 mL of methanol, shake for 4 hours, allow to stand and use the supernatant liquid as the sample solution. Separately, take 0.010 g of the acrylic acid reference standard, dissolve in methanol to make exactly 200 mL and use the solution as the standard solution. Perform the test with 5 μ L each of the sample solution and standard solution as directed under Gas Chromatography. Determine the peak heights, H_t and H_s , of acrylic acid of respective solutions: H_t is not higher than H_s .

Method 2

To 1.0 g of this substance, add 250 mL of saline, stir for 2 hours, filter, and use the resultant solution as the sample solution. Separately, take 0.20 g of acrylic acid reference standard, dissolve in saline to make exactly 100 mL. To 1 mL of the solution, add saline to make exactly 250 mL and use as the standard solution. Perform the test with 20 μ L each of the sample solution and the standard solution as directed under Liquid Chromatography. Determine the peak heights, H_t and H_s , of acrylic acid of respective solutions: H_t is not higher than H_s .

Loss on drying: Not more than 15% (2.0 g, 105°C, 3 hours)

Residue on ignition: Not more than 76% (Method 1)

Absorbency

Take 1.0 g of this substance in a nylon woven fabric (10 cm in width, 20 cm in length, 255 mesh), immerse in 1000 mL of saline for 1 hour, allow to stand for 10 minutes, remove excessive water and determine absorbency: it absorbs more than 10 times its weight.

Note) Identify acrylic acid according to Method 1 or Method 2.

Acetate Fiber

Definition

Acetate Fiber is a cellulose fiber obtained by partially saponifying acetylated cellulose.

Description

It occurs as colorless to light yellow fibrous substances, and it is odorless.

Identification

- (1) Determine the infrared absorption spectrum of this substance as directed in the film method under Infrared Spectrophotometry: it exhibits absorption at the wave numbers of about 3440 cm^{-1} , 2920 cm^{-1} , 1760 cm^{-1} , 1360 cm^{-1} , 1240 cm^{-1} , 1040 cm^{-1} and 900 cm^{-1} .

- (2) When burned, it softens, shrinks, and burns gradually. Solid and black mass remains, but it can be crushed with a hand easily.

Specific gravity: 1.30-1.32

Melting point: 260°C

Purity

- (1) Heavy metals: Not more than 20 ppm (Method 2)
(2) Arsenic: Not more than 2 ppm (Method 2)

Loss on drying: Not more than 8.0% (2.0 g, 105°C, 3 hours)

Residue on ignition: Not more than 2.5% (Method 2)

Alkyl Ketene Dimer Emulsion

Definition

Alkyl Ketene Dimer Emulsion is an emulsion obtained by the emulsification of alkyl ketene dimer.

Description

It is a white liquid, and it is odorless or has a faint, characteristic odor.

Identification

Determine the infrared absorption spectrum of this substance, previously dried at 105°C for 3 hours, as directed in the potassium bromide disk method under Infrared Spectrophotometry: it exhibits absorption at the wave numbers of about between 3000 cm⁻¹ and 2800 cm⁻¹, 1850 cm⁻¹, 1720 cm⁻¹ and 1470 cm⁻¹.

pH: 3.0-4.5

Purity

- (1) Heavy metals: Not more than 10 ppm (Method 2)
(2) Arsenic: Not more than 2 ppm (Method 2)

Alkenyl Succinic Anhydride Solution

Definition

Alkenyl Succinic Anhydride Solution is obtained by the maleinization of alkenyl succinic anhydride and maleic anhydride. It is saponified with potassium hydroxide.

Description

It is a red brown to light red brown liquid, and it has a faint, characteristic odor.

Identification

Determine the infrared absorption spectrum of this substance, previously dried at 105°C for about 2 hours, as directed in the film method under Infrared Spectrophotometry: it exhibits absorption at the wave numbers of about between 3000 cm⁻¹ and 2800 cm⁻¹, 1570 cm⁻¹, and 1410 cm⁻¹.

pH: 7.0-9.5

Purity

- (1) Heavy metals: Not more than 10 ppm (Method 2)
(2) Arsenic: Not more than 2 ppm (Method 2)

Sulfur

Definition

Sulfur, when dried, contains not less than 99.5% of sulfur (S).

Description

It occurs as a light yellow, fine, amorphous or crystalline powder, and it is odorless.

Identification

Ignite this substance: it burns with a blue flame and gives a characteristic odor of sulfur dioxide.

Purity

(1) Acidity or alkalinity

To 2.0 g of this substance, add 10 mL of water, shake and filter: the solution is neutral.

(2) Arsenic

To 0.2 g of this substance, add 10 mL of ammonia TS, stir for 3 hours, filter, evaporate the filtrate on a water bath to dryness, add 1 mL of nitric acid and evaporate the solution to dryness again. To the residue, add 5 mL of water, and perform the test using this solution as the sample solution: not more than 10 ppm.

Loss on drying: Not more than 1.0% (1.0 g, silica gel, 4 hours)

Residue on ignition: Not more than 0.3% (Method 1)

Assay

Weigh accurately about 1 g of this substance, previously dried, add 50 mL of potassium hydroxide-ethanol TS, dissolve by boiling, allow to cool and add water to make 250 mL. To 25 mL of this solution, add 50 mL of hydrogen peroxide TS and heat on a water bath for 1 hour. Acidify with dilute hydrochloric acid, add 200 mL of water and add dropwise hot barium chloride TS while boiling until no more precipitate is produced. Heat the mixture on a water bath for 1 hour, filter the precipitate, and wash thoroughly with water. Ignite the precipitate to constant mass, weigh the residue as barium sulfate (BaSO_4 233.40). Perform a blank determination in the same manner, and make any necessary correction.

$$\text{Amount (mg) of S} = \text{amount (mg) of barium sulfate (BaSO}_4) \times 0.1374$$

Urethane Fiber

Definition

Urethane Fiber is a fiber obtained by the reaction of polytetramethylene ether glycol with diphenylmethane diisocyanate, followed by dilution with dimethylacetamide solvent and polymerization with amine compound.

Description

It occurs as a white elastomer and it is odorless.

Identification

Dissolve this substance in dimethylacetamide (1 in 5), and determine the infrared absorption spectrum of this substance as directed in the film method under Infrared Spectrophotometry: it exhibits absorption at the wave numbers of about between 3500 cm^{-1} and 3250 cm^{-1} , between 1750 cm^{-1} and 1690 cm^{-1} , between 1575 cm^{-1} and 1500 cm^{-1} , and 1100 cm^{-1} (ether bond).

Melting point: Not less than 225°C (with decomposition)

Purity

(1) Coloring matter

Immerse 10 g of this substance in 100 mL of ethanol, allow to cool, stir for about 10 minutes and filter. Transfer 50 mL of the filtrate into a Nessler tube and observe downward: the filtrate is colorless and clear.

(2) Acidity or alkalinity

To 1 g of this substance, add 300 mL of freshly boiled and cooled water and allow to cool. To 25 mL of the solution, add 3 drops of phenolphthalein TS: no red color develops. Separately, to 25 mL of the same solution, add 1 drop of methyl orange TS: no red color develops.

(3) Fluorescence

Irradiate this substance with ultraviolet rays (main wavelength: 365 nm) in a dark place: it shows neither marked fluorescence nor fluorescence by contamination.

(4) Residual isocyanate

Weigh accurately 0.3 g of this substance, add 3 mL of methanol, extract at 70°C for 3 hours, and use the extract as the sample solution. Separately, to 0.02 g of diphenylmethane diisocyanate, add methanol to make exactly 100 mL. To 1 mL of this solution, add methanol to make 10 mL, and use this solution as the standard solution. Perform the test with 5 µL each of the sample solution and the standard solution as directed under Liquid Chromatography according to the following conditions: the peak area of the product obtained by the reaction of isocyanate and methanol from the sample solution is not larger than the peak area of the product obtained by the reaction of isocyanate and methanol from the standard solution.

Operating conditions

Detector: An ultraviolet absorption photometer (wavelength: 246 nm)

Column: A stainless steel column, 4.6 mm in inside diameter and 15 cm in length, packed with octadecylsilanized silica gel for liquid chromatography

Mobile phase: To 50 mL of acetonitrile, add 50 mL of water.

Flow rate: 1.0 mL/min (Adjust it so that the retention time of the product obtained by the reaction of isocyanate and methanol is about 5 minutes)

(5) Heavy metals: Not more than 20 ppm (Method 2)

Residue on ignition: Not more than 5% (Method 3)

Urethane Film

Definition

Urethane Film is a film obtained by the extrusion molding of molten polyurethane.

Description

It occurs as a translucent elastomer and it is practically odorless.

Identification

Determine the infrared absorption spectrum of this substance as directed in the film method under Infrared

Spectrophotometry: it exhibits absorption at the wave numbers of about between 3400 cm^{-1} and 3300 cm^{-1} , 1740 cm^{-1} , 1530 cm^{-1} , and between 1170 cm^{-1} and 1070 cm^{-1} .

Purity

(1) Coloring matter

Immerse 10 g of this substance in 100 mL of freshly boiled and cooled water, stir and filter. Transfer 50 mL of the filtrate into a Nessler tube and observe downward: the filtrate is almost colorless.

(2) Acidity or alkalinity

Transfer 25 mL of the filtrate (1) into a test tube 15 mm in inside diameter and add 3 drops of phenolphthalein TS: no red color develops. Separately, to 25 mL of the same solution, add 1 drop of methyl orange TS: no red color develops.

(3) Fluorescence

Irradiate this substance with ultraviolet rays (main wavelength: 365 nm) in a dark place: it shows neither marked fluorescence nor fluorescence by contamination.

(4) Heavy metals: Not more than 20 ppm (Method 2)

Urethane Foam

Definition

Urethane Foam is a soft polyester polyol urethane foam.

Description

It occurs as a white porous elastomer and it is odorless.

Identification

(1) Confirmation of urethane bond

Take about 0.2 g of this substance in a test tube and stopper loosely with absorbent cotton. Decompose this substance by heating the test tube over a low flame, immerse the absorbent cotton in a solution of p-dimethylaminobenzaldehyde in methanol (1 in 100) and acidify with 1 drop of dilute hydrochloric acid: a bright yellow color develops.

(2) Confirmation of ester bond

Take about 0.05 g of this substance in a test tube, add several drops of a solution of potassium hydroxide in methanol (11.2 in 100) and several drops of a saturated solution of hydroxylamine hydrochloride in methanol. Add several drops of phenolphthalein TS and confirm this mixture is alkaline. Heat the mixture on a water bath for 20-40 seconds, allow to cool about 1 minute and acidify with 1 mol/L hydrochloric acid TS. To this solution, add ferric chloride solution (2 in 100): a purple color develops.

pH

To 1.0 g of this substance, add 100 mL of freshly boiled and cooled water, press out and determine the pH as directed under pH Determination: it is between 6.0 and 7.5.

Melting point: 225-240°C (Method 1, with decomposition)

Purity

(1) Heavy metals: Not more than 20 ppm (Method 2)

(2) Unreacted monomer

To 1.0 g of this substance, previously dried, add benzene solution of dibenzylamine (1 in 100,000) to make exactly 100 mL, and heat on a hot bath for 1 hour. After cooling, press to collect the extract. Immerse the extract in 50 mL of benzene, and press to collect the extract, and repeat this three more times. Evaporate the extract to dryness under reduced pressure, add 1 mL of methanol, and use this solution as the sample solution. Separately, to 0.020 g of isophorone diisocyanate, add benzene to make exactly 100 mL. To 1 mL of the solution, add benzene solution of dibenzylamine (1 in 100,000) to make exactly 100 mL, and heat on a hot bath for 1 hour. After cooling, evaporate it to dryness under reduced pressure, add 1 mL of methanol, and use this solution as the standard solution. Perform the test with 20 μ L each of the sample solution and standard solution as directed under Liquid Chromatography according to the following conditions. Determine the peak heights, H_t and H_s, of isophorone diisocyanate of respective solutions: H_t is not higher than H_s.

Operating conditions

Detector: An ultraviolet absorption photometer (wavelength: 265 nm)

Column: A stainless steel column, 4.6 mm in inside diameter and 150 mm in length, packed with 6- μ m silica gel chemically bounded with an octadecyl group

Mobile phase: To 85 mL of methanol, add 15 mL of water.

Flow rate: 0.7mL/min (Adjust the flow rate so that the retention time of the product obtained by the reaction of isophorone diisocyanate and dibenzylamine is about 10 minutes)

Detection sensitivity: Adjust it so that the peak height of isophorone diisocyanate obtained from 20 μ L of the standard solution is 5 to 10 mm.

Residue on ignition: 0.2% (Method 1)

Ester Gum

Definition

Ester Gum is an ester compound of the derivatives of rosin or its polymer.

Description

It occurs as a light yellow to light brown glass mass or clear viscous liquid, and it is odorless or has a faint, characteristic odor.

Identification

- (1) To 0.1 g of this substance, add 10 mL of acetic anhydride, dissolve by heating in a water bath, allow to cool and add 1 drop of sulfuric acid: a purple-red color develops.
- (2) To 1 g of this substance, add 5 mL of sodium hydroxide solution (1 in 25) and 5 mL of water and shake vigorously: a white to light yellow turbidity and a lasting foam is produced.

Purity

- (1) Clarity of solution

Dissolve 10 g of this substance in 10 mL of toluene at 70-75°C, filter while warming and allow the

solution to stand for 24 hours: the solution is clear.

- (2) Acid value: Not more than 18.0 (Method 1)

Weigh accurately about 3 g of this substance, dissolve in 50 mL of a mixture of benzene and ethanol (2:1), and perform the test with this solution as the sample solution.

- (3) Heavy metals: Not more than 40 ppm (0.50 g, Method 2, Standard Lead Solution 2.0 mL)

- (4) Arsenic: Not more than 4 ppm (0.25 g, Method 2)

Residue on ignition: Not more than 0.1% (2.0 g, Method 1)

Ethylene-Ethyl Acrylate Copolymer (EEA)

Definition

Ethylene-Ethyl Acrylate Copolymer (EEA) is an ethylene-ethyl acrylate copolymer resin obtained by copolymerizing of ethylene and ethyl acrylate.

Description

It occurs as translucent powder or granules, and it is practically odorless.

Identification

Determine the infrared absorption spectrum of this substance as directed in the film method under Infrared Spectrophotometry: it exhibits absorption at the wave numbers of about between 3000 cm^{-1} and 2900 cm^{-1} , 1740 cm^{-1} , 1460 cm^{-1} , 1378 cm^{-1} , 1160 cm^{-1} , 1140 cm^{-1} , 730 cm^{-1} , and 720 cm^{-1} .

Specific gravity: 0.91-0.98

Melting point: 60-100°C

Purity

- (1) Clarity and color of solution

Dissolve 1 g of this substance in 50 mL of xylene by heating: the solution is colorless and clear.

- (2) Heavy metals: Not more than 20 ppm (Method 2)

- (3) Arsenic: Not more than 2 ppm (Method 2)

Residue on ignition: Not more than 0.1% (5.0 g, Method 1)

Ethylene-Acrylic Acid Copolymer (EAA)

Definition

Ethylene-Acrylic Acid Copolymer (EAA) is an ethylene-acrylic acid copolymer resin obtained by copolymerizing ethylene and acrylic acid.

Description

It occurs as translucent powder or granules, and it is practically odorless.

Identification

Determine the infrared absorption spectrum of this substance as directed in the film method under Infrared Spectrophotometry: it exhibits absorption at the wave numbers of about 2960 cm^{-1} , 2870 cm^{-1} , 1379 cm^{-1} , 730 cm^{-1} , 722 cm^{-1} and 720 cm^{-1} .

Specific gravity: 0.94-0.98

Melting point: 80-100°C

Purity

- (1) Clarity and color of solution

Dissolve 1 g of this substance in 50 mL of xylene by heating: the solution is colorless and clear.

- (2) Heavy metals: Not more than 20 ppm (Method 2)

- (3) Arsenic: Not more than 2 ppm (Method 2)

Residue on ignition: Not more than 0.1% (5.0 g, Method 1)

Ethylene-Octene-1 Copolymer

Definition

Ethylene-Octene-1 Copolymer is an ethylene-octene-1 copolymer resin obtained by copolymerizing ethylene and octene-1.

Description

It occurs as translucent powder or granules, and it is practically odorless.

Identification

Determine the infrared absorption spectrum of this substance as directed in the film method under Infrared Spectrophotometry: it exhibits absorption at the wave numbers of about 2960 cm⁻¹, 2870 cm⁻¹, 1460 cm⁻¹, 1378 cm⁻¹, 899 cm⁻¹, 730 cm⁻¹ and 720 cm⁻¹.

Specific gravity: 0.85-0.94

Melting point: 115-130°C

Purity

- (1) Clarity and color of solution

Dissolve 1 g of this substance in 50 mL of xylene by heating: the solution is colorless and clear.

- (2) Heavy metals: Not more than 20 ppm (Method 2)

- (3) Arsenic: Not more than 2 ppm (Method 2)

Residue on ignition: Not more than 0.1% (5.0 g, Method 1)

Ethylene-Vinyl Acetate Copolymer (EVA) (1)

Definition

Ethylene-Vinyl Acetate Copolymer (EVA) (1) is an ethylene-vinyl acetate copolymer obtained by heating and polymerizing ethylene and vinyl acetate under high pressure using organic peroxide as a reaction initiator.

Description

- (1) It occurs as a milky white pelleted or powdered solid.
- (2) It is soluble in toluene and xylene, and practically insoluble in water.

Identification

Determine the infrared absorption spectrum of this substance as directed in the film method under Infrared Spectrophotometry: it exhibits absorption at the wave numbers of about 1740 cm⁻¹ and 1470 cm⁻¹.

Purity

- (1) Clarity of solution

Dissolve 1 g of this substance in 100 mL of hot xylene: the solution is clear.

- (2) Heavy metals: Not more than 10 ppm (Method 2)

Loss on drying: Not more than 0.5% (1.0 g, 80°C, 4 hours)

Residue on ignition: Not more than 0.5% (30 g, 900°C, 90 minutes)

Ethylene-Vinyl Acetate Copolymer (EVA) (2)

Definition

Ethylene-Vinyl Acetate Copolymer (EVA) (2) is a copolymer resin obtained by radical reaction of ethylene and vinyl acetate (3% to 40%).

Description

It occurs as translucent powder or granules, and it is practically odorless.

Identification

Determine the infrared absorption spectrum of this substance as directed in the film method under Infrared Spectrophotometry: it exhibits absorption at the wave numbers of about 2920 cm^{-1} , 2850 cm^{-1} , 1735 cm^{-1} , 1470 cm^{-1} , 1370 cm^{-1} , 1235 cm^{-1} , 1020 cm^{-1} and 720 cm^{-1} .

Specific gravity: 0.91-0.98

Melting point: 60-100°C

Purity

- (1) Clarity and color of solution

Dissolve 1 g of this substance in 50 mL of xylene by heating: the solution is colorless and clear.

- (2) Heavy metals: Not more than 20 ppm (Method 2)

- (3) Arsenic: Not more than 2 ppm (Method 2)

Residue on ignition: Not more than 0.1% (5.0 g, Method 1)

Ethylene-Vinyl Acetate Copolymer Emulsion

Definition

Ethylene-Vinyl Acetate Copolymer Emulsion is a copolymer emulsion obtained by the emulsion polymerization of ethylene and vinyl acetate under medium pressure.

Description

It is a milky white liquid, and it is odorless or has a faint, characteristic odor.

Identification

Determine the infrared absorption spectrum of this substance as directed in the film method under Infrared Spectrophotometry: it exhibits absorption at the wave numbers of about between 2900 cm^{-1} and 2850 cm^{-1} , 1740 cm^{-1} , 1240 cm^{-1} , and 610 cm^{-1} .

pH: 4.0-7.0

Purity

- (1) Heavy metals: Not more than 10 ppm (Method 2)

(2) Arsenic: Not more than 2 ppm (Method 2)

Residue on ignition: Not more than 0.4% (Method 1)

Ethylene-Vinyl Acetate/Polypropylene Bicomponent Fiber

Definition

Ethylene-Vinyl Acetate/Polypropylene Bicomponent Fiber is a polypropylene-core/ethylene-vinyl acetate copolymer-sheath or side-by-side bicomponent fiber.

Description

It occurs as colorless to white fibrous substances, and it is odorless.

Identification

Determine the infrared absorption spectrum of this substance as directed in the film method under Infrared Spectrophotometry: it exhibits absorption at the wave numbers of about 2880 cm^{-1} , 2820 cm^{-1} , 1740 cm^{-1} , 1450 cm^{-1} , 1360 cm^{-1} , 1240 cm^{-1} , 1010 cm^{-1} , 720 cm^{-1} and 600 cm^{-1} .

Specific gravity: 0.93-0.98

Melting point: 90-110°C

Purity

(1) Heavy metals: Not more than 20 ppm (Method 2)

(2) Arsenic: Not more than 2 ppm (Method 2)

Residue on ignition: Not more than 2.5% (Method 2)

Ethylene-Butene Copolymer (EBR)

Definition

Ethylene-Butene Copolymer (EBR) is an ethylene-butene copolymer resin obtained by copolymerizing ethylene and butene.

Description

It occurs as translucent powder or granules, and it is practically odorless.

Identification

Determine the infrared absorption spectrum of this substance as directed in the film method under Infrared Spectrophotometry: it exhibits absorption at the wave numbers of about 2960 cm^{-1} , 2870 cm^{-1} , 1379 cm^{-1} , 772 cm^{-1} , 730 cm^{-1} and 720 cm^{-1} .

Specific gravity: 0.85-0.90

Melting point: 120-130°C

Purity

(1) Clarity and color of solution

Dissolve 1 g of this substance in 50 mL of xylene by heating: the solution is colorless and clear.

(2) Heavy metals: Not more than 20 ppm (Method 2)

(3) Arsenic: Not more than 2 ppm (Method 2)

Residue on ignition: Not more than 0.1% (5.0 g, Method 1)

Ethylene-Propylene Copolymer (EPR)

Definition

Ethylene-Propylene Copolymer (EPR) is an ethylene-propylene copolymer resin obtained by copolymerizing ethylene and propylene.

Description

It occurs as translucent powder or granules, and it is practically odorless.

Identification

Determine the infrared absorption spectrum of this substance as directed in the film method under Infrared Spectrophotometry: it exhibits absorption at the wave numbers of about 2960 cm^{-1} , 2870 cm^{-1} , 1735 cm^{-1} , 1460 cm^{-1} , 1377 cm^{-1} , 1150 cm^{-1} , 937 cm^{-1} , 730 cm^{-1} and 720 cm^{-1} .

Specific gravity: 0.85-0.88

Melting point: 120-130°C

Purity

(1) Clarity and color of solution

Dissolve 1 g of this substance in 50 mL of xylene by heating: the solution is colorless and clear.

(2) Heavy metals: Not more than 20 ppm (Method 2)

(3) Arsenic: Not more than 2 ppm (Method 2)

Residue on ignition: Not more than 0.1% (5.0 g, Method 1)

Ethylene-Pentene-1 Copolymer

Definition

Ethylene-Pentene-1 Copolymer is an ethylene-pentene-1 copolymer resin obtained by copolymerizing ethylene and pentene-1.

Description

It occurs as translucent powder or granules, and it is practically odorless.

Identification

Determine the infrared absorption spectrum of this substance as directed in the film method under Infrared Spectrophotometry: it exhibits absorption at the wave numbers of about 2960 cm^{-1} , 2870 cm^{-1} , 1460 cm^{-1} , 1378 cm^{-1} , 894 cm^{-1} , 730 cm^{-1} and 720 cm^{-1} .

Specific gravity: 0.85-0.94

Melting point: 120-130°C

Purity

(1) Clarity and color of solution

Dissolve 1 g of this substance in 50 mL of xylene by heating: the solution is colorless and clear.

(2) Heavy metals: Not more than 20 ppm (Method 2)

(3) Arsenic: Not more than 2 ppm (Method 2)

Residue on ignition: Not more than 0.1% (5.0 g, Method 1)

Ethylene-Methacrylic Acid Copolymer (EMAA)

Definition

Ethylene-Methacrylic Acid Copolymer (EMAA) is an ethylene-methacrylic acid copolymer resin obtained by copolymerizing ethylene and methacrylic acid.

Description

It occurs as translucent powder or granules, and it is practically odorless.

Identification

Determine the infrared absorption spectrum of this substance as directed in the film method under Infrared Spectrophotometry: it exhibits absorption at the wave numbers of about 2960 cm^{-1} , 2870 cm^{-1} , 1710 cm^{-1} , 1460 cm^{-1} , 730 cm^{-1} and 720 cm^{-1} .

Specific gravity: 0.92-0.98

Melting point: 80-105°C

Purity

(1) Clarity and color of solution

Dissolve 1 g of this substance in 50 mL of xylene by heating: the solution is colorless and clear.

(2) Heavy metals: Not more than 20 ppm (Method 2)

(3) Arsenic: Not more than 2 ppm (Method 2)

Residue on ignition: Not more than 0.1% (5.0 g, Method 1)

Ethylene-Methyl Methacrylate Copolymer (EMMA)

Definition

Ethylene-Methyl Methacrylate Copolymer (EMMA) is an ethylene-methyl methacrylate copolymer resin obtained by copolymerizing ethylene and methyl methacrylate.

Description

It occurs as translucent powder or granules, and is practically odorless.

Identification

Determine the infrared absorption spectrum of this substance as directed in the film method under Infrared Spectrophotometry: it exhibits absorption at the wave numbers of about 3440 cm^{-1} , between 3000 cm^{-1} and 2900 cm^{-1} , 1378 cm^{-1} , 1190 cm^{-1} , 1140 cm^{-1} and 720 cm^{-1} .

Specific gravity: 0.92-0.95

Melting point: 60-110°C

Purity

(1) Clarity and color of solution

Dissolve 1 g of this substance in 50 mL of xylene by heating: the solution is colorless and clear.

(2) Heavy metals: Not more than 20 ppm (Method 2)

(3) Arsenic: Not more than 2 ppm (Method 2)

Residue on ignition: Not more than 0.1% (5.0 g, Method 1)

Ethylene-4-Methylpentene-1 Copolymer

Definition

Ethylene-4-Methylpentene-1 Copolymer is an ethylene-4-methylpentene-1 copolymer resin obtained by copolymerizing ethylene and 4-methylpentene-1.

Description

It occurs as translucent powder or granules, and is practically odorless.

Identification

Determine the infrared absorption spectrum of this substance as directed in the film method under Infrared Spectrophotometry: it exhibits absorption at the wave numbers of about 2960 cm^{-1} , 2870 cm^{-1} , 1460 cm^{-1} , 1384 cm^{-1} , 1366 cm^{-1} , 1169 cm^{-1} , 920 cm^{-1} , 730 cm^{-1} and 720 cm^{-1} .

Specific gravity: 0.85-0.94

Melting point: 120-130°C

Purity

- (1) Clarity and color of solution

Dissolve 1 g of this substance in 50 mL of xylene by heating: the solution is colorless and clear.

- (2) Heavy metals: Not more than 20 ppm (Method 2)

- (3) Arsenic: Not more than 2 ppm (Method 2)

Residue on ignition: Not more than 0.1% (5.0 g, Method 1)

Chemical Pulp

Definition

Chemical Pulp is obtained by the chemical treatment of fiber to separate the fibers.

Description

It is white in color, practically odorless, and contains no foreign matter.

Purity

- (1) Lignin

Dissolve 0.1 g of phloroglucin in 15 mL of hydrochloric acid, add water to make 20 mL and drop onto this substance: no marked pink or red color develops.

- (2) Coloring matter

Immerse 10 g of this substance in 100 mL of freshly boiled and cooled water, stir and filter. Transfer 50 mL of the filtrate into a Nessler tube and observe downward: the filtrate is almost colorless.

- (3) Acidity or alkalinity

Transfer 10 mL of the filtrate (2) into a test tube 15 mm in inside diameter and add 2 drops of phenolphthalein TS: no red color develops. Separately, to 10 mL of the same solution, add 1 drop of methyl orange TS: no red color develops.

- (4) Fluorescence

Irradiate this substance with ultraviolet rays (main wavelength: 365 nm) in a dark place: it shows neither

marked fluorescence nor fluorescence by contamination.

Total ash: Not more than 0.65% (5.0 g)

Active Carbon

Definition

Active Carbon is obtained by activating carbon substance such as plant-based fibers treated with oxidizing gas or chemicals at high temperature.

Description

It occurs as black powder, granules or fibrous substances, and it is odorless.

Identification

- (1) If this substance is a powder, use it as it is. If it is in a granular or fibrous state, pulverize well to powder. Take about 0.1 g of this substance in a powder state, add 10 mL of dilute methylene blue TS and 2 drops of hydrochloric acid (1 in 4), shake well and filter with a dry filter paper for quantitative analysis (5C): the filtrate is colorless.
- (2) Take about 0.5 g of this substance in a powder state in a test tube and heat over a direct flame while supplying air: it burns without any flame. Pass the evolved gas through calcium hydroxide TS: a white turbidity is produced.

Purity

- (1) Color and acidity or alkalinity of solution
To 3.0 g of this substance, add 60 mL of water, boil for 5 minutes, cool, add water to make 60 mL and filter: the filtrate is colorless and neutral.
- (2) Heavy metals: Not more than 50 ppm (0.50 g, Method 2, Standard Lead Solution 2.5 mL)
- (3) Arsenic: Not more than 2 ppm (Method 2)

Flocculent Sodium Carboxymethylcellulose

Definition

Flocculent Sodium Carboxymethylcellulose is flocculent fiber made from the sodium salt of carboxymethylether of parts of fiber structure of plant-based fibers.

Description

- (1) It is white in color, odorless, and contains no foreign matter.
- (2) It does not remarkably contain broken pieces of pericarp and seed, or nep.

Identification

It becomes slightly viscous when water is added.

Purity

- (1) Coloring matter
Immerse 10 g of this substance in 100 mL of ethanol, press out, transfer 50 mL of the extract into a Nessler tube and observe downward: a yellow color may develop but neither blue nor green color develops.
- (2) Acidity or alkalinity

To 10 g of this substance, add 100 mL of freshly boiled and cooled water and allow to cool. To 25 mL of the solution, add 3 drops of phenolphthalein TS: no red color develops. Separately, to 25 mL of the same solution, add 1 drop of methyl orange TS: no red color develops.

(3) Fluorescence

Irradiate this substance with ultraviolet rays (main wavelength: 365 nm) in a dark place: it shows neither marked fluorescence nor fluorescence by contamination.

(4) Sedimentation velocity

Prepare a test basket, weighing about 3 g from copper wire 0.4 mm in diameter (No. 26) in the form of a cylinder 50 mm in diameter and 80 mm in depth, with 20-mm intervals between the wires. Place 5.0 g of this substance in the test basket, drop the basket on its side gently into the water about 200 mm in depth at ordinary temperature from the height of about 10 mm above the water surface: the basket sinks in water within 8 seconds.

Total ash: Not more than 5.6% (5.0 g)

Absorbent Paper

Definition

Absorbent Paper is a paper made of chemical pulp.

Description

(1) It is white in color, odorless, and contains no foreign matter.

(2) It does not remarkably contain undissociated fibers.

Purity

(1) Lignin

Dissolve 0.1 g of phloroglucin in 15 mL of hydrochloric acid, add water to make 20 mL and drop onto this substance: no marked pink or red color develops.

(2) Coloring matter

Immerse 10 g of this substance in 100 mL of ethanol, press out, transfer 50 mL of the extract into a Nessler tube and observe downward: a yellow color may develop but neither blue nor green color develops.

(3) Acidity or alkalinity

To 10 g of this substance, add 100 mL of freshly boiled and cooled water and allow to cool. To 25 mL of the solution, add 3 drops of phenolphthalein TS: no red color develops. Separately, to 25 mL of the same solution, add 1 drop of methyl orange TS: no red color develops.

(4) Fluorescence

Irradiate this substance with ultraviolet rays (main wavelength: 365 nm) in a dark place: it shows neither marked fluorescence nor fluorescence by contamination.

(5) Sedimentation velocity

Prepare a test basket, weighing about 3 g from copper wire 0.4 mm in diameter (No. 26) in the form of a cylinder 50 mm in diameter and 80 mm in depth, with 20-mm intervals between the wires. Place 5.0 g of

this substance in the test basket, drop the basket on its side gently into the water about 200 mm in depth at ordinary temperature from the height of about 10 mm above the water surface: the basket sinks in water within 8 seconds.

Total ash: Not more than 0.65% (5.0 g)

High-density Polyethylene (HDPE)

Definition

High-density Polyethylene (HDPE) is a straight-chain high-density polyethylene resin obtained by the polymerization of ethylene.

Description

It occurs as translucent powder or granules, and it is practically odorless.

Identification

Determine the infrared absorption spectrum of this substance as directed in the film method under Infrared Spectrophotometry: it exhibits absorption at the wave numbers of about 2960 cm^{-1} , 2870 cm^{-1} , 1460 cm^{-1} , 730 cm^{-1} and 720 cm^{-1} .

Specific gravity: 0.85-1.00

Melting point: 115-140°C

Purity

(1) Clarity and color of solution

Dissolve 1 g of this substance in 50 mL of xylene by heating: the solution is colorless and clear.

(2) Heavy metals: Not more than 20 ppm (Method 2)

(3) Arsenic: Not more than 2 ppm (Method 2)

Residue on ignition: Not more than 0.1% (5.0 g, Method 1)

Cycloaliphatic Saturated Hydrocarbon Resin

Definition

Cycloaliphatic Saturated Hydrocarbon Resin is a hydrogenated C_9 -group petroleum resin. The mean molecular weight is 550 to 900.

Description

It occurs as an almost colorless clear glass mass, and it is odorless or has a faint, characteristic odor.

Specific gravity: 0.98-1.03

Identification

Dissolve about 1.0 g of this substance in 5 mL of chloroform and determine the infrared absorption spectrum of this substance as directed in the film method under Infrared Spectrophotometry: it exhibits absorption at the wave numbers of about 2930 cm^{-1} , 1450 cm^{-1} , 1380 cm^{-1} and 760 cm^{-1} .

Heavy metals: Not more than 10 ppm (Method 2)

Loss on drying: Not more than 1.0% (2.0 g, 105°C, 2 hours)

Residue on ignition: Not more than 0.01% (50 g, 800°C, 3 hours)

Cycloparaffin

Definition

Cycloparaffin is a mixture of liquid hydrocarbons obtained from petroleum.

Description

It is a colorless to light yellow liquid, and it is odorless or has a faint, characteristic odor.

Specific gravity: d_4^{15} 0.81-0.94

Purity

(1) Acidity or alkalinity

To 10 mL of this substance, add 10 mL of hot water and 1 drop of phenolphthalein TS, and shake vigorously: no red color develops. Separately, to 10 mL of this substance, add 10 mL of hot water and 1 drop of methyl orange TS: no red color develops.

(2) Sulfur compounds

To 4 mL of this substance, add 2 mL of ethanol (99.5) and 2 drops of a transparent sodium hydroxide solution (1 in 5) saturated with lead monoxide, heat at 70°C for 10 minutes with occasional shaking, and allow to cool: no dark brown color develops.

(3) Polynuclear aromatic hydrocarbons

Transfer 25 mL of this substance into a 100-mL separator using a 25-mL measuring cylinder, wash the measuring cylinder with 25 mL of n-hexane for ultraviolet-visible spectrophotometry, combine the washings with the liquid in the separator, and shake well. Shake this solution vigorously with 5.0 mL of dimethylsulfoxide for ultraviolet-visible spectrophotometry for 2 minutes, and allow to stand for 15 minutes. Transfer the lower layer into a 50-mL separator, add 2 mL of n-hexane for ultraviolet-visible spectrophotometry, shake vigorously for 2 minutes and allow to stand for 2 minutes. Transfer the lower layer into a glass-stoppered 10-mL centrifuge tube, centrifuge at the rate between 2500 and 3000 rpm for about 10 minutes. Transfer the clear solution so obtained into a cell, stopper tightly, and use this solution as the sample solution. Separately, transfer 25 mL of n-hexane for ultraviolet-visible spectrophotometry into another 50-mL separator, shake vigorously with 5.0 mL of dimethylsulfoxide for ultraviolet-visible spectrophotometry for 2 minutes, and allow to stand for 2 minutes. Transfer the lower layer into a glass-stoppered 10-mL centrifuge tube, centrifuge at the rate between 2500 and 3000 rpm for about 10 minutes. Transfer the clear solution so obtained into a cell, and stopper tightly. Immediately determine the absorbance of the sample solution using this solution as the blank: it is not more than 4.0 at the wavelength between 260 and 350 nm.

(4) Heavy metals: Not more than 10 ppm (2.0 g, Method 3, Standard Lead Solution 2.0 mL)

(5) Arsenic: Not more than 2 ppm (Method 2)

Dibenzothiazyl Disulfide

Definition

Dibenzothiazyl Disulfide is di(benzothiazolyl-2)disulfide ($C_{14}H_8N_2S_4$ 332.49) obtained by the reaction of an

aqueous solution of the alkali salt of 2-mercaptobenzothiazole with oxidants such as bromine.

Description

It occurs as a white to light yellow powder, and it is not soluble in water and ethanol, but soluble in toluene and chloroform.

Identification

Take 0.1 g of this substance in a volumetric flask and dissolve in chloroform to make 100 mL. Perform the test with 5 μ L of this solution as directed under Liquid Chromatography: a peak is observed at the retention time of about 22.6 minutes.

Operating conditions

Detector: An ultraviolet absorption photometer (wavelength: 254 nm)

Column: A stainless steel column, 4.6 mm in inside diameter and 25 cm in length, packed with octadecylsilanized silica gel

Flow rate: 0.8 mL/min

Melting point: 165-175°C

Purity

- (1) Heavy metals: Not more than 20 ppm (Method 2)
- (2) Arsenic: Not more than 2 ppm (Method 2)

Residue on ignition: Not more than 0.5% (Method 1)

Aliphatic Hydrocarbon Resin

Definition

Aliphatic Hydrocarbon Resin is a C₅-group petroleum hydrocarbon resin. The mean molecular weight is 500 to 2000.

Description

- (1) It occurs as a white to light yellowish brown easily-breakable solid, and it is odorless or has a faint, characteristic odor.
- (2) It is freely soluble in toluene, and practically insoluble in water and ethanol.

Specific gravity: 1.03-1.06

Identification

Mix this substance, previously pulverized, with potassium bromide powder, solidify to plate-like shape, and determine the infrared absorption spectrum of this substance as directed in the potassium bromide disk method under Infrared Spectrophotometry: it exhibits absorption at the wave numbers of about between 2970 cm⁻¹ and 2950 cm⁻¹ and 1300 cm⁻¹.

Heavy metals: Not more than 10 ppm (Method 2)

Loss on drying: Not more than 1.0% (2.0 g, 105°C, 2 hours)

Residue on ignition: Not more than 0.01% (1.0 g, 450-550°C)

Aliphatic and Aromatic Copolymer Resin

(Aromatic and Denatured Aliphatic Hydrocarbon Resin)

Definition

Aliphatic and Aromatic Copolymer Resin (Aromatic and Denatured Aliphatic Hydrocarbon Resin) is obtained by the copolymerization of a C₅-group resin and an aromatic resin. The mean molecular weight is 400 to 1500.

Description

- (1) It occurs as a light yellow solid or viscous liquid, and it is practically odorless.
- (2) It is practically insoluble in water and ethanol, but freely soluble in tetrahydrofuran and diethyl ether.

Identification

Dissolve 1 g of this substance in 10 mL of toluene, apply onto a potassium bromide disk, evaporate the toluene to obtain a film and determine the infrared absorption spectrum of this substance as directed in the film method under Infrared Spectrophotometry: it exhibits absorption at the wave numbers of about between 2970 cm⁻¹ and 2950 cm⁻¹, 1600 cm⁻¹, 1460 cm⁻¹, 1370 cm⁻¹ and 700 cm⁻¹.

Purity

- (1) Clarity of solution

Dissolve 150 g of this substance in 400 mL of tetrahydrofuran: the solution is clear.

- (2) Heavy metals: Not more than 10 ppm (Method 2)

Loss on drying: Not more than 3% (5.0 g, 105°C, 4 hours)

Residue on ignition: Not more than 0.01% (30 g, 600°C)

Aliphatic Saturated Hydrocarbon Resin

Definition

Aliphatic Saturated Hydrocarbon Resin is a hydrogenated C₅-group petroleum resin. The mean molecular weight is 300 to 600.

Description

It is an almost colorless clear viscous liquid, and it is odorless or has a faint, characteristic odor.

Specific gravity: d_4^{15} 0.90-0.95

Identification

Dissolve about 1 g of this substance in 5 mL of chloroform and determine the infrared absorption spectrum of this substance as directed in the film method under Infrared Spectrophotometry: it exhibits absorption at the wave numbers of about 2930 cm⁻¹, 1450 cm⁻¹, 1380 cm⁻¹ and 760 cm⁻¹.

Heavy metals: Not more than 10 ppm (Method 2)

Loss on drying: Not more than 1.0% (2.0 g, 105°C, 2 hours)

Residue on ignition: Not more than 0.1% (50 g, 800°C, 3 hours)

Hydrogenated Aliphatic and Aromatic Copolymer Resin

Definition

Hydrogenated Aliphatic and Aromatic Copolymer Resin is obtained by the copolymerization and hydrogenation of a C₅-group resin and an aromatic resin. The mean molecular weight is 500 to 1000.

Description

It occurs as a colorless clear pellet or flake solid, and it is odorless or has a faint, characteristic odor. It is freely soluble in toluene, xylene and diethyl ether, but practically insoluble in water and ethanol.

Identification

Mix completely 1 mg of this substance and 100 to 200 mg of dried potassium bromide for infrared spectrophotometry, and determine the infrared absorption spectrum of this substance as directed in the potassium bromide disk method under Infrared Spectrophotometry: it exhibits absorption at the wave numbers of about 3650 cm^{-1} , 2930 cm^{-1} , 2850 cm^{-1} , 2790 cm^{-1} , 2670 cm^{-1} , 2600 cm^{-1} , 1746 cm^{-1} , 1449 cm^{-1} , 1375 cm^{-1} , 890 cm^{-1} , 843 cm^{-1} , 757 cm^{-1} and 700 cm^{-1} .

Heavy metals: Not more than 10 ppm (Method 2)

Loss on drying: Not more than 1.0% (2.0 g, 105°C , 2 hours)

Residue on ignition: Not more than 0.02% (5.0 g, 850°C , 30 minutes)

Hydrogenated Dicyclopentadiene-group Hydrocarbon Resin

Definition

Hydrogenated Dicyclopentadiene-group Hydrocarbon Resin is a solid resin obtained by the hydrogenation of a dicyclopentadiene-based polymer. The mean molecular weight is 300 to 700.

Description

It occurs as a colorless, clear, easily-breakable solid, and it is odorless.

It is freely soluble in tetrahydrofuran and toluene, but practically insoluble in water and ethanol.

Acid value: Not more than 0.1 (Method 1)

Weigh accurately 2 g of this substance and dissolve it in a 40-mL mixture of toluene and isopropyl alcohol (2:1), and perform the test with this solution.

Specific gravity: 1.05-1.08

Identification

Mix this substance, previously pulverized, with potassium bromide powder, solidify to plate-like shape, and determine the infrared absorption spectrum of this substance as directed in the potassium bromide disk method under Infrared Spectrophotometry: it exhibits absorption at the wave numbers of about between 2970 cm^{-1} and 2950 cm^{-1} , 1463 cm^{-1} and 1373 cm^{-1} .

Purity

(1) Clarity of solution

Dissolve 150 g of this substance in 400 mL of tetrahydrofuran: the solution is clear.

(2) Heavy metals: Not more than 10 ppm (Method 2)

Loss on drying: Not more than 1% (5.0 g, 105°C , 4 hours)

Residue on ignition: Not more than 0.01% (30 g, 600°C)

Styrene-Isoprene-Styrene Block Copolymer

Definition

Styrene-Isoprene-Styrene Block Copolymer is a ternary block copolymer of polystyrene, polyisoprene and polystyrene. The mean molecular weight is 80000 to 200000.

Description

It occurs as a white to light yellow elastic pellet, crumb or powder solid, and it is odorless or has a faint, characteristic odor.

It is freely soluble in tetrahydrofuran, diethyl ether, and toluene, but practically insoluble in water and ethanol.

Identification

Dissolve 1 g of this substance in 10 mL of toluene, apply 1 drop of this solution onto a potassium bromide disk, evaporate the solvent to obtain a film and determine the infrared absorption spectrum of this substance as directed in the film method under Infrared Spectrophotometry: it exhibits absorption at the wave numbers of about 2960 cm^{-1} , 2850 cm^{-1} , 1600 cm^{-1} , 1452 cm^{-1} , 1375 cm^{-1} , and 837 cm^{-1} .

Viscosity

Dissolve 50.0 g of this substance in 150 g of toluene, use the solution as the sample solution, and measure viscosity twice: the mean viscosity is 100 - 1700 mPa·s. (Brookfield type viscometer, No. 3, 10-60 rotations, $30\pm 1^\circ\text{C}$, 1 minute)

Purity

(1) Clarity and color of solution

Dissolve 1.0 g of this substance in 100 mL of toluene: the solution is colorless and clear.

(2) Extractable substances

To 5.0 g of this substance, add 80 mL of water, and boil under a reflux condenser for 30 minutes. After cooling, filter the extract, and add water to the filtrate to make exactly 100 mL. Use this solution as the sample solution for the following tests.

1) pH: 6.0-9.0

2) Chloride

Perform the test with 10 mL of the sample solution as directed under Chloride Limit Test: not more than 0.085%. Prepare the control solution with 1.2 mL of 0.01 mol/L hydrochloric acid

3) Heavy metals: Not more than 20 ppm (20 mL of the sample solution, Method 1, Standard Lead Solution 2 mL)

4) Potassium permanganate-reducing substances

Transfer 25 mL of the sample solution into a glass-stoppered, Erlenmyer flask, add 10.0 mL of 0.002 mol/L potassium permanganate VS and 5 mL of dilute sulfuric acid, and boil for 3 minutes. After cooling, add 0.10 g of potassium iodide, stopper tightly, shake, and allow to stand for 10 minutes. Titrate the solution with 0.01 mol/L sodium thiosulfate VS (indicator: 5 drops of starch TS). Perform the test in the same manner, using 25 mL of the blank solution, and obtain the difference of the consumption of 0.002 mol/L potassium permanganate VS between these solutions: not more than 2.0 mL.

(3) Styrene

Weigh exactly 5.0 g of this substance, and dissolve in 50 mL of tetrahydrofuran. Add methanol to make

exactly 100 mL, shake vigorously for 10 minutes, centrifuge and use the supernatant liquid as the sample solution. Separately, weigh exactly 0.10 g of styrene, and add methanol to make exactly 100 mL. Measure exactly 5 mL of the solution, and add methanol to make exactly 100 mL. Measure exactly 1 mL of the solution, add 50 mL of tetrahydrofuran, mix well, add methanol to make exactly 100 mL, and use this solution as the standard solution. Perform the test with 100 µL each of the sample solution and standard solution as directed under Liquid Chromatography according to the following conditions. Determine each peak area from these solutions by the automatic integration method: the peak area of styrene from the sample solution is not larger than the peak area of styrene from the standard solution.

Operating conditions

Detector: An ultraviolet absorption photometer (wavelength: 268 nm)

Column: A stainless steel column, about 4 mm in inside diameter and about 15 cm in length, packed with 10-µm octadecylsilylated silica gel for liquid chromatography

Column temperature: A constant temperature of about 25°C

Mobile phase: A mixture of water and tetrahydrofuran (1:1)

Flow rate: Adjust the flow rate so that the retention time of styrene is about 5 minutes.

Detection sensitivity: Adjust it so that the peak height of styrene obtained from 100 µL of the standard solution is not less than 5 mm.

(4) Lithium

Take 1.0 g of this substance in a crucible, and ignite at 450°C to 500°C to incinerate. After cooling, dissolve the residue in 2 mL of 0.1 mol/L hydrochloric acid TS, add 10 mL of water, and filter through a glass filter (G4). To this filtrate, add water to make exactly 200 mL, and use this solution as the sample solution. Separately, measure exactly 1.0 mL of Standard Lithium Solution for Atomic Absorption Spectrophotometry, and add water to make exactly 100 mL. Measure exactly 10 mL of this solution, add 2 mL of 0.1 mol/L hydrochloric acid TS, add water to make exactly 100 mL, and use this solution as the standard solution. Perform the test with the sample solution and the standard solution as directed under Atomic Absorption Spectrophotometry according to the following conditions: the absorbance of the sample solution is not more than that of the standard solution.

Gas: Combustible gas-Acetylene

Supporting gas-Air

Lamp: Lithium hollow-cathode lamp

Wavelength: 670.8nm

Loss on drying: Not more than 1.0% (0.1 g, 105°C, 4 hours)

Residue on ignition: Not more than 2.0% (1 g)

Styrene-Ethylene-Butylene-Styrene Block Copolymer

Definition

Styrene-Ethylene-Butylene-Styrene Block Copolymer is a block copolymer of polystyrene-polyethylene butylene-polystyrene, obtained by the hydrogenation of a copolymer consisting of a polystyrene-

polybutadiene-polystyrene block. The mean molecular weight is 30000 to 300000.

Description

It occurs as a white to light yellow elastic pellet, crumb or powder solid, and it is odorless or has a faint, characteristic odor.

It is freely soluble in tetrahydrofuran, diethyl ether, and toluene, but practically insoluble in water and ethanol.

Identification

Dissolve 1 g of this substance in 10 mL of toluene, apply 1 drop of this solution onto a potassium bromide disk, evaporate the solvent to obtain a film and determine the infrared absorption spectrum of this substance as directed in the film method under Infrared Spectrophotometry: it exhibits absorption at the wave numbers of about 2920 cm^{-1} , 2850 cm^{-1} , 1601 cm^{-1} , 1380 cm^{-1} , 760 cm^{-1} and 700 cm^{-1} .

Viscosity

Dissolve 50.0 g of this substance in 150 g of toluene, remove air bubbles, use the solution as the sample solution, and measure viscosity twice: the mean viscosity is 100 - 10000 mPa·s. (Brookfield type viscometer, No. 3, 10-60 rotations, $25\pm 1^\circ\text{C}$, 1 minute)

Purity

(1) Clarity and color of solution

Dissolve 1.0 g of this substance in 100 mL of toluene: the solution is colorless and clear.

(2) Extractable substances

To 5.0 g of this substance, add 80 mL of water, and boil under a reflux condenser for 30 minutes. After cooling, filter the extract, and add water to the filtrate to make exactly 100 mL. Use this solution as the sample solution for the following tests.

1) pH: 5.0-9.0

2) Chloride

Perform the test with 10 mL of the sample solution as directed under Chloride Limit Test: not more than 0.085%. Prepare the control solution with 1.2 mL of 0.01 mol/L hydrochloric acid

3) Heavy metals: Not more than 20 ppm (20 mL of the sample solution, Method 1, Standard Lead Solution 2 mL)

4) Potassium permanganate-reducing substances

Transfer 25 mL of the sample solution into a glass-stoppered, Erlenmeyer flask, add 10.0 mL of 0.002 mol/L potassium permanganate VS and 5 mL of dilute sulfuric acid, and boil for 3 minutes. After cooling, add 0.10 g of potassium iodide, stopper tightly, shake and allow to stand for 10 minutes. Titrate the solution with 0.01 mol/L sodium thiosulfate VS (indicator: 5 drops of starch TS). Perform the test in the same manner, using 25 mL of the blank solution, and obtain the difference of the consumption of 0.002 mol/L potassium permanganate VS between these solutions: not more than 2.0 mL.

(3) Styrene

Weigh exactly 5.0 g of this substance, and dissolve in 50 mL of tetrahydrofuran. Add methanol to make exactly 100 mL, shake vigorously for 10 minutes, centrifuge and use the supernatant liquid as the sample

solution. Separately, weigh exactly 0.10 g of styrene, and add methanol to make exactly 100 mL. Measure exactly 5 mL of the solution, and add methanol to make exactly 100 mL. Measure exactly 1 mL of the solution, add 50 mL of tetrahydrofuran, mix well, add methanol to make exactly 100 mL, and use this solution as the standard solution. Perform the test with 100 μ L each of the sample solution and standard solution as directed under Liquid Chromatography according to the following conditions. Determine each peak area from these solutions by the automatic integration method: the peak area of styrene from the sample solution is not larger than the peak area of styrene from the standard solution.

Operating conditions

Detector: An ultraviolet absorption photometer (wavelength: 268 nm)

Column: A stainless steel column, about 4 mm in inside diameter and about 15 cm in length, packed with 10- μ m octadecylsilanized silica gel for liquid chromatography

Column temperature: A constant temperature of about 25°C

Mobile phase: A mixture of water and tetrahydrofuran (1:1)

Flow rate: Adjust the flow rate so that the retention time of styrene is about 5 minutes.

Detection sensitivity: Adjust it so that the peak height of styrene obtained from 100 μ L of the standard solution is not less than 5 mm.

(4) Lithium

Take 1.0 g of this substance in a crucible, and ignite at 450°C to 500°C to incinerate. After cooling, dissolve it in 2 mL of 0.1 mol/L hydrochloric acid TS, add 10 mL of water, and filter through a glass filter (G4). To this filtrate add water to make exactly 200 mL, and use this solution as the sample solution.

Separately, measure exactly 1.0 mL of Standard Lithium Solution for Atomic Absorption

Spectrophotometry, and add water to make exactly 100 mL. Measure exactly 10 mL of this solution, add 2 mL of 0.1 mol/L hydrochloric acid TS, add water to make exactly 100 mL, and use this solution as the standard solution. Perform the test with the sample solution and the standard solution as directed under Atomic Absorption Spectrophotometry according to the following conditions: the absorbance of the sample solution is not more than that of the standard solution.

Gas: Combustible gas-Acetylene

Supporting gas-Air

Lamp: Lithium hollow-cathode lamp

Wavelength: 670.8nm

Loss on drying: Not more than 1.0% (1.0 g, 105°C, 4 hours)

Residue on ignition: Not more than 2.0% (Method 1)

Styrene-Ethylene-Propylene-Styrene Block Copolymer

Definition

Styrene-Ethylene-Propylene-Styrene Block Copolymer is a block copolymer of polystyrene-polyethylene propylene-polystyrene, obtained by the hydrogenation of a copolymer consisting of a polystyrene-polyisoprene-polystyrene block or styrene-poly(isoprene/butadiene)-polystyrene. The mean molecular weight

is 30000 to 300000.

Description

It occurs as a white to light yellow elastic pellet, crumb or powder solid, and it is odorless or has a faint, characteristic odor.

It is freely soluble in tetrahydrofuran, diethyl ether, and toluene, but practically insoluble in water and ethanol.

Identification

Dissolve 1 g of this substance in 10 mL of toluene, apply 1 drop of this solution onto a potassium bromide disk, evaporate the solvent to obtain a film and determine the infrared absorption spectrum of this substance as directed in the film method under Infrared Spectrophotometry: it exhibits absorption at the wave numbers of about 2920 cm^{-1} , 2850 cm^{-1} , 1601 cm^{-1} , 1380 cm^{-1} , 760 cm^{-1} and 700 cm^{-1} .

Viscosity

Dissolve 50.0 g of this substance in 150 g of toluene, remove air bubbles, use the solution as the sample solution, and measure viscosity twice: the mean viscosity is 150 - 20000 mPa·s. (Brookfield type viscometer, No. 3, 10-60 rotations, $25\pm 1^\circ\text{C}$, 1 minute)

Purity

(1) Clarity and color of solution

Dissolve 1.0 g of this substance in 100 mL of toluene: the solution is colorless and clear.

(2) Extractable substances

To 5.0 g of this substance, add 80 mL of water, and boil under a reflux condenser for 30 minutes. After cooling, filter the extract, and add water to the filtrate to make exactly 100 mL. Use this solution as the sample solution for the following tests.

1) pH: 5.0-9.0

2) Chloride

Perform the test with 10 mL of the sample solution as directed under Chloride Limit Test: not more than 0.085%. Prepare the control solution with 1.2 mL of 0.01 mol/L hydrochloric acid

3) Heavy metals: Not more than 20 ppm (20 mL of the sample solution, Method 1, Standard Lead Solution 2 mL)

4) Potassium permanganate-reducing substances

Transfer 25 mL of the sample solution into a glass-stoppered, Erlenmyer flask, add 10.0 mL of 0.002 mol/L potassium permanganate VS and 5 mL of dilute sulfuric acid, and boil for 3 minutes. After cooling, add 0.10 g of potassium iodide, stopper tightly, shake and allow to stand for 10 minutes. Titrate the solution with 0.01 mol/L sodium thiosulfate VS (indicator: 5 drops of starch TS). Perform the test in the same manner, using 25 mL of the blank solution, and obtain the difference of the consumption of 0.002 mol/L potassium permanganate VS between these solutions: not more than 2.0 mL.

(3) Styrene

Weigh exactly 5.0 g of this substance, and dissolve in 50 mL of tetrahydrofuran. Add methanol to make exactly 100 mL, shake vigorously for 10 minutes, centrifuge and use the supernatant liquid as the sample

solution. Separately, weigh exactly 0.10 g of styrene, and add methanol to make exactly 100 mL. Measure exactly 5 mL of the solution, and add methanol to make exactly 100 mL. Measure exactly 1 mL of the solution, add 50 mL of tetrahydrofuran, mix well, add methanol to make exactly 100 mL, and use this solution as the standard solution. Perform the test with 100 μ L each of the sample solution and standard solution as directed under Liquid Chromatography according to the following conditions. Determine each peak area from these solutions by the automatic integration method: the peak area of styrene from the sample solution is not larger than the peak area of styrene from the standard solution.

Operating conditions

Detector: An ultraviolet absorption photometer (wavelength: 268 nm)

Column: A stainless steel column, about 4 mm in inside diameter and about 15 cm in length, packed with 10- μ m octadecylsilanized silica gel for liquid chromatography

Column temperature: A constant temperature of about 25°C

Mobile phase: A mixture of water and tetrahydrofuran (1:1)

Flow rate: Adjust the flow rate so that the retention time of styrene is about 5 minutes.

Detection sensitivity: Adjust it so that the peak height of styrene obtained from 100 μ L of the standard solution is not less than 5 mm.

(4) Lithium

Take 1.0 g of this substance in a crucible, and ignite at 450°C to 500°C to incinerate. After cooling, dissolve it in 2 mL of 0.1 mol/L hydrochloric acid TS, add 10 mL of water, and filter through a glass filter (G4). To this filtrate add water to make exactly 200 mL, and use this solution as the sample solution.

Separately, measure exactly 1.0 mL of Standard Lithium Solution for Atomic Absorption

Spectrophotometry, and add water to make exactly 100 mL. Measure exactly 10 mL of this solution, add 2 mL of 0.1 mol/L hydrochloric acid TS, add water to make exactly 100 mL, and use this solution as the standard solution. Perform the test with the sample solution and the standard solution as directed under Atomic Absorption Spectrophotometry according to the following conditions: the absorbance of the sample solution is not more than that of the standard solution.

Gas: Combustible gas-Acetylene

Supporting gas-Air

Lamp: Lithium hollow-cathode lamp

Wavelength: 670.8nm

Loss on drying: Not more than 1.0% (1.0 g, 105°C, 4 hours)

Residue on ignition: Not more than 2.0% (Method 1)

Styrene-Butadiene-Styrene Block Copolymer

Definition

Styrene-Butadiene-Styrene Block Copolymer is a block copolymer of polystyrene and polybutadiene. The mean molecular weight is 30000 to 300000.

Description

It occurs as a white to light yellow elastic pellet, crumb or powder solid, and it is odorless or has a faint, characteristic odor.

It is freely soluble in tetrahydrofuran and toluene, but practically insoluble in water and ethanol.

Identification

Dissolve 1 g of this substance in 10 mL of toluene, apply 1 drop of this solution onto a potassium bromide disk, evaporate the solvent to obtain a film and determine the infrared absorption spectrum of this substance as directed in the film method under Infrared Spectrophotometry: it exhibits absorption at the wave numbers of about 2960 cm^{-1} , 2850 cm^{-1} , 1600 cm^{-1} , 1452 cm^{-1} , 965 cm^{-1} , 910 cm^{-1} , and 700 cm^{-1} .

Viscosity

Dissolve 50.0 g of this substance in 150 g of toluene, use the solution as the sample solution, and measure viscosity twice: the mean viscosity is 200 - 20000 mPa·s. (Brookfield type viscometer, No. 3, 10-60 rotations, $25\pm 1^\circ\text{C}$, 1 minute)

Purity

(1) Clarity and color of solution

Dissolve 1.0 g of this substance in 100 mL of toluene: the solution is colorless and clear.

(2) Extractable substances

To 5.0 g of this substance, add 80 mL of water, and boil under a reflux condenser for 30 minutes. After cooling, filter the extract, and add water to the filtrate to make exactly 100 mL. Use this solution as the sample solution for the following tests.

1) pH: 5.0-9.0

2) Chloride

Perform the test with 10 mL of the sample solution as directed under Chloride Limit Test: not more than 0.085%. Prepare the control solution with 1.2 mL of 0.01 mol/L hydrochloric acid

3) Heavy metals: Not more than 20 ppm (20 mL of the sample solution, Method 1, Standard Lead Solution 2 mL)

4) Potassium permanganate-reducing substances

Transfer 25 mL of the sample solution into a glass-stoppered, Erlenmyer flask, add 10.0 mL of 0.002 mol/L potassium permanganate VS and 5 mL of dilute sulfuric acid, and boil for 3 minutes. After cooling, add 0.10 g of potassium iodide, stopper tightly, shake and allow to stand for 10 minutes. Titrate the solution with 0.01 mol/L sodium thiosulfate VS (indicator: 5 drops of starch TS). Perform the test in the same manner, using 25 mL of the blank solution, and obtain the difference of the consumption of 0.002 mol/L potassium permanganate VS between these solutions: not more than 2.0 mL.

(3) Styrene

Weigh exactly 5.0 g of this substance, and dissolve in 50 mL of tetrahydrofuran. Add methanol to make exactly 100 mL, shake vigorously for 10 minutes, centrifuge and use the supernatant liquid as the sample solution. Separately, weigh exactly 0.10 g of styrene, and add methanol to make exactly 100 mL. Measure exactly 5 mL of the solution, and add methanol to make exactly 100 mL. Measure exactly 1 mL of the

solution, add 50 mL of tetrahydrofuran, mix well, add methanol to make exactly 100 mL, and use this solution as the standard solution. Perform the test with 100 µL each of the sample solution and standard solution as directed under Liquid Chromatography according to the following conditions. Determine each peak area from these solutions by the automatic integration method: the peak area of styrene from the sample solution is not larger than the peak area of styrene from the standard solution.

Operating conditions

Detector: An ultraviolet absorption photometer (wavelength: 268 nm)

Column: A stainless steel column, about 4 mm in inside diameter and about 15 cm in length, packed with 10-µm octadecylsilylated silica gel for liquid chromatography

Column temperature: A constant temperature of about 25°C

Mobile phase: A mixture of water and tetrahydrofuran (1:1)

Flow rate: Adjust the flow rate so that the retention time of styrene is about 5 minutes.

Detection sensitivity: Adjust it so that the peak height of styrene obtained from 100 µL of the standard solution is not less than 5 mm.

(4) Lithium

Take 1.0 g of this substance in a crucible, and ignite at 450°C to 500°C to incinerate. After cooling, dissolve it in 2 mL of 0.1 mol/L hydrochloric acid TS, add 10 mL of water, and filter through a glass filter (G4). To this filtrate add water to make exactly 200 mL, and use this solution as the sample solution.

Separately, measure exactly 1.0 mL of Standard Lithium Solution for Atomic Absorption

Spectrophotometry, and add water to make exactly 100 mL. Measure exactly 10 mL of this solution, add 2 mL of 0.1 mol/L hydrochloric acid TS, add water to make exactly 100 mL, and use this solution as the standard solution. Perform the test with the sample solution and the standard solution as directed under Atomic Absorption Spectrophotometry according to the following conditions: the absorbance of the sample solution is not more than that of the standard solution.

Gas: Combustible gas-Acetylene

Supporting gas-Air

Lamp: Lithium hollow-cathode lamp

Wavelength: 670.8nm

Loss on drying: Not more than 1.0% (1.0 g, 105°C, 4 hours)

Residue on ignition: Not more than 2.0% (Method 1)

Styrene-Methacrylate Copolymer Solution

Definition

Styrene-Methacrylate Copolymer Solution is an aqueous solution obtained by quaternizing copolymers of styrene and methacrylic acid esters with epichlorohydrin.

Description

It is a white to milky white liquid, and it has a faint odor of acetic acid.

Identification

Determine the infrared absorption spectrum of this substance, previously dried at 105°C for about 2 hours, as directed in the film method under Infrared Spectrophotometry: it exhibits absorption at the wave numbers of about 2920 cm⁻¹, 1730 cm⁻¹, 1490 cm⁻¹, 1450 cm⁻¹, 1380 cm⁻¹, 760 cm⁻¹ and 700 cm⁻¹.

pH: 4.0 - 6.0 (1 in 10)

Purity

- (1) Heavy metals: Not more than 10 ppm (Method 2)
- (2) Arsenic: Not more than 2 ppm (Method 2)
- (3) Epichlorohydrin

To 50 g of this substance, add 200 mL of water, and extract the solution with 30 mL of diethyl ether 5 times. Combine the ether extracts, wash with 30 mL of water, dehydrate with 5 g of anhydrous sodium sulfate, and evaporate the ether. Dissolve the residue in 5 mL of acetone, and use this solution as the sample solution. Separately, take 5 mL of acetone solution of epichlorohydrin (1 in 10000) and use this solution as the standard solution. Perform the test with each of the sample solution and standard solution as directed under Gas Chromatography according to the following conditions: the peak area of epichlorohydrin from the sample solution is not larger than the peak area of epichlorohydrin from the standard solution.

Operating conditions

Detector: Hydrogen flame-ionization detector

Column: A column 3-4 mm in inside diameter packed with siliceous earth for gas chromatography (177 to 250 µm) coated with polyethylene glycol 20 M in 10%

Column temperature: From 80 to 140°C

Heating rate: 10°C/min

Carrier gas and flow rate: Adjust the flow rate so that the retention time of nitrogen and epichlorohydrin is about 4 minutes.

Injection volume of sample: 10 µL

Hydrophobic Zeolite

Definition

Hydrophobic Zeolite is hydrophobic zeolite obtained by the reaction of sodium silicate and sodium aluminate.

Description

It is white in color, practically odorless, and contains no foreign matter.

Identification

- (1) To 0.1 g of this substance, add 1 mL of 1 mol/L hydrochloric acid, disperse by ultrasonication for 30 seconds, and boil for 5 minutes. After cooling, add 2 mL of water, and filter the solution through a membrane filter with a pore size of 0.45 µm. Add ammonia TS to the filtrate until a white, gelatinous precipitate is produced. Add 5 drops of alizarin S TS: the precipitate changes to red.
- (2) Prepare a bead by fusing ammonium sodium hydrogenphosphate tetrahydrate on a platinum loop. Place the bead in contact with this substance and fuse again: an infusible matter appears in the bead, which

changes to an opaque bead with a web-like structure upon cooling.

Purity

(1) Acidity or alkalinity

To 5.0 g of this substance, add 70 mL of water, shake vigorously and boil for 5 minutes. After cooling, add water to make 100 mL, shake well, and centrifuge: the supernatant liquid is neutral.

(2) Heavy metals

Disperse 1.0 g of this substance in 2 mL of water, add 10 mL of dilute hydrochloric acid, shake well, and filter. Wash the residue with 10 mL of water, combine the washing with the filtrate. Add ammonia solution (28) dropwise until a precipitate just appears, and add dropwise dilute hydrochloric acid with vigorous shaking to redissolve the residue. To the solution, add 0.15 g of hydroxylamine hydrochloride, and heat. After cooling, add 0.15 g of sodium acetate, 2 mL of dilute acetic acid and water to make 50 mL. Perform the test using this solution as the sample solution as directed in Method 4: not more than 30 ppm. To 3.0 mL of Standard Lead Solution, add 0.15 g of hydroxylamine hydrochloride, 0.15 g of sodium acetate, 2 mL of dilute acetic acid and water to make 50 mL, and use this solution as the control solution.

(3) Arsenic

Disperse 0.4 g of this substance in 1 mL of water, add 10 mL of dilute hydrochloric acid, and shake well. Perform the test using this solution as the sample solution: not more than 5 ppm.

Loss on drying: Not more than 4.0% (1 g, 105°C, 2 hours)

Absorbent Cotton

Definition

Absorbent Cotton is defatted cotton.

Description

- (1) It is white in color, odorless, and contains no foreign matter.
- (2) It does not remarkably contain broken pieces of pericarp and seed, or nep.

Identification

It is soluble in ammonium copper TS.

Purity

(1) Coloring matter

Immerse 10 g of this substance in 100 mL of ethanol, press out, transfer 50 mL of the extract into a Nessler tube and observe downward: a yellow color may develop but neither blue nor green color develops.

(2) Acidity or alkalinity

Immerse 10 g of this substance in 100 mL of freshly boiled and cooled water. To 25 mL of the solution, add 3 drops of phenolphthalein TS: no red color develops. Separately, to 25 mL of the same solution, add 1 drop of methyl orange TS: no red color develops.

(3) Fluorescence

Irradiate this substance with ultraviolet rays (main wavelength: 365 nm) in a dark place: it shows neither marked fluorescence nor fluorescence by contamination.

(4) Sedimentation velocity

Prepare a test basket, weighing about 3 g from copper wire 0.4 mm in diameter (No. 26) in the form of a cylinder 50 mm in diameter and 80 mm in depth, with 20-mm intervals between the wires. Place 5.0 g of this substance in the test basket, drop the basket on its side gently into the water about 200 mm in depth at ordinary temperature from the height of about 10 mm above the water surface: the basket sinks in water within 8 seconds.

Total ash: Not more than 0.25% (5.0 g)

Calcium Carbonate

Definition

Calcium Carbonate is manufactured by milling ore of calcium carbonate.

Description

Calcium Carbonate occurs as a white powder. It is odorless.

Identification

Add 0.5 g of Calcium Carbonate to 30 mL of dilute hydrochloric acid: it dissolves with effervescence. Boil this solution and neutralize with ammonia TS: the solution responds to the Qualitative Tests for calcium salt.

Purity

(1) Acid-insoluble substances

To about 5.0 g of Calcium Carbonate, weighed accurately, add about 70 mL of water, then add 10 mL of hydrochloric acid in small portions with stirring, and boil for 5 minutes. After cooling, filter this solution through a filter paper for quantitative analysis (Class 5 C), and wash the residue with hot water until the last washing shows no response for chloride with silver nitrate TS. Ignite the residue together with the filter paper to constant mass, cool the ash in a desiccator (silica gel), and weigh accurately: it is not more than 0.5%.

(2) Barium

With the filtrate in (1), perform the test as directed under Flame Coloration Test: no green color develops.

(3) Heavy metals

Mix 2.0 g of Calcium Carbonate with 5 mL of water, add slowly 6 mL of hydrochloric acid, and evaporate on a water bath to dryness. Dissolve the residue in 50 mL of water, and filter. To 25 mL of the filtrate add 2 mL of dilute acetic acid, 1 drop of ammonia TS and water to make 50 mL, and perform the test using this solution as the sample solution (not more than 20 ppm).

Prepare the control solution with 2.0 mL of Standard Lead Solution.

(4) Arsenic

To 0.40 g of Calcium Carbonate add 10 mL of dilute hydrochloric acid, warm, and perform the test using this solution as the sample solution (not more than 5 ppm).

Loss on drying: Not more than 2.0% (1 g, 180°C, 4 hours)

Linear Low-density Polyethylene (LLDPE)

Definition

Linear Low-density Polyethylene (LLDPE) is a straight-chain low-density polyethylene resin with short-chain branches obtained by the polymerization of ethylene.

Description

It occurs as translucent powder or granules, and it is practically odorless.

Identification

Determine the infrared absorption spectrum of this substance as directed in the film method under Infrared Spectrophotometry: it exhibits absorption at the wave numbers of about 2960 cm⁻¹, 2870 cm⁻¹, 1460 cm⁻¹, 730 cm⁻¹ and 720 cm⁻¹.

Specific gravity: 0.85-0.94

Melting point: 90-130°C

Purity

(1) Clarity and color of solution

Dissolve 1 g of this substance in 50 mL of xylene by heating: the solution is colorless and clear.

(2) Heavy metals: Not more than 20 ppm (Method 2)

(3) Arsenic: Not more than 2 ppm (Method 2)

Residue on ignition: Not more than 0.1% (5.0 g, Method 1)

Low-density Polyethylene (LDPE)

Definition

Low-density Polyethylene (LDPE) is a branched low-density polyethylene resin with long-chain branches obtained by the polymerization of ethylene.

Description

It occurs as translucent powder or granules, and it is practically odorless.

Identification

Determine the infrared absorption spectrum of this substance as directed in the film method under Infrared Spectrophotometry: it exhibits absorption at the wave numbers of about 2960 cm⁻¹, 2870 cm⁻¹, 1460 cm⁻¹, 1384 cm⁻¹, 1379 cm⁻¹, 1366 cm⁻¹, 730 cm⁻¹ and 720 cm⁻¹.

Specific gravity: 0.85-0.94

Melting point: 90-120°C

Purity

(1) Clarity and color of solution

Dissolve 1 g of this substance in 50 mL of xylene by heating: the solution is colorless and clear.

(2) Heavy metals: Not more than 20 ppm (Method 2)

(3) Arsenic: Not more than 2 ppm (Method 2)

Residue on ignition: Not more than 0.1% (5.0 g, Method 1)

Natural Rubber Thread

Definition

Natural Rubber Thread is obtained by vulcanization of natural rubber.

Description

It occurs as a white elastomer, is practically odorless, and contains no foreign matter.

Purity

(1) Coloring matter

Immerse 10 g of this substance in 100 mL of freshly boiled and cooled water, stir and filter. Transfer 50 mL of the filtrate into a Nessler tube and observe downward: the filtrate is almost colorless.

(2) Acidity or alkalinity

Transfer 10 mL of the filtrate (1) into a test tube 15 mm in inside diameter and add 2 drops of phenolphthalein TS: no red color develops. Separately, to 10 mL of the same solution, add 1 drop of methyl orange TS: no red color develops.

(3) Fluorescence

Irradiate this substance with ultraviolet rays (main wavelength: 365 nm) in a dark place: it shows neither marked fluorescence nor fluorescence by contamination.

Elasticity

Cut this substance into a 1.5-5.0-mm piece, hold both edges of the thread 100 mm apart and apply a 75-g load: it does not break within 1 minute.

Partial Sodium Salt of Starch-Acrylic Acid Graft Polymer

Definition

Partial Sodium Salt of Starch-Acrylic Acid Graft Polymer is a water-absorbing resin consisting of slightly cross-linked partial sodium salts of starch-acrylic acid graft polymer as a principal component.

Description

(1) It occurs as a white powder and it is practically odorless.

(2) It swells with water but is practically insoluble in water.

(3) Melting point: Not less than 200°C (with decomposition)

Identification

(1) To 1.0 g of this substance, add 100 mL of water, stir and allow to stand for 10 minutes: the solution becomes gelatinous.

(2) To 10 g of the gelatinous substance (1), add 1 mL of calcium chloride TS and shake: a white precipitate is produced.

(3) To 10 g of the gelatinous substance (1), add 1 mL of magnesium sulfate TS and shake: a white precipitate

is produced.

- (4) To 10 g of the gelatinous substance (1), add 1 mL of cobalt chloride solution (1 in 25), add 2 or 3 drops of ammonium chloride TS and shake: a light red precipitate is produced. Dry the precipitate: the color changes to purple.
- (5) To 10 g of the gelatinous substance (1), add 3 drops of iodine TS: a dark blue-purple color is produced.

Purity

- (1) Coloring matter

Immerse this substance in ethanol not less than 10 times the mass of this substance, stir for 10 minutes and filter: the filtrate is a colorless clear liquid.

- (2) Acidity or alkalinity

To 1.0 g of this substance, add 500 mL of freshly boiled and cooled water and allow to cool. To 25 mL of this solution, add 3 drops of phenolphthalein TS: no red color develops. Separately, to 25 mL of the solution, add 1 drop of methyl orange TS: a yellow color develops.

- (3) Fluorescence

Irradiate this substance with ultraviolet rays (main wavelength: 365 nm) in a dark place: it shows no marked fluorescence.

- (4) Heavy metals: Not more than 20 ppm (Method 2)
- (5) Acrylic acid

Method 1

To 5.0 g of this substance, add exactly 10 mL of methanol, shake for 4 hours, allow to stand and use the supernatant liquid as the sample solution. Separately, take 0.010 g of the acrylic acid reference standard, dissolve in methanol to make exactly 200 mL and use the solution as the standard solution. Perform the test with 5 μ L each of the sample solution and standard solution as directed under Gas Chromatography. Determine the peak heights, H_t and H_s , of acrylic acid of respective solutions: H_t is not higher than H_s .

Method 2

To 1.0 g of this substance, add 250 mL of saline, stir for 2 hours, filter, and use the resultant solution as the sample solution. Separately, take 0.20 g of acrylic acid reference standard, dissolve in saline to make exactly 100 mL. To 1 mL of the solution, add saline to make exactly 250 mL and use as the standard solution. Perform the test with 20 μ L each of the sample solution and the standard solution as directed under Liquid Chromatography. Determine the peak heights, H_t and H_s , of acrylic acid of respective solutions: H_t is not higher than H_s .

Loss on drying: Not more than 15% (2.0 g, 105°C, 3 hours)

Residue on ignition: Not more than 76% (Method 1)

Absorbency

Take 1.0 g of this substance in a nylon woven fabric (10 cm in width, 20 cm in length, 255 mesh), immerse in 1000 mL of saline for 1 hour, allow to stand for 10 minutes, remove excessive water and determine absorbency: it absorbs more than 10 times its weight.

Note) Identify acrylic acid according to Method 1 or Method 2.

Cuprammonium Rayon

Definition

Cuprammonium Rayon is a cellulose fiber obtained by recycling cellulose by cuprammonium method.

Description

It occurs as colorless to light yellow fibrous substances, and it is odorless.

Identification

Determine the infrared absorption spectrum of this substance as directed in the potassium bromide disk method under Infrared Spectrophotometry: it exhibits absorption at the wave numbers of about between 3450 cm^{-1} and 3250 cm^{-1} , 2900 cm^{-1} , 1650 cm^{-1} , between 1430 cm^{-1} and 1370 cm^{-1} , between 1060 cm^{-1} and 970 cm^{-1} and 890 cm^{-1} .

Specific gravity: 1.49-1.51

Melting point: 260-300°C (with decomposition)

Purity

- (1) Heavy metals: Not more than 20 ppm (Method 2)
- (2) Arsenic: Not more than 2 ppm (Method 2)

Loss on drying

Allow to stand this substance at 20°C and 65% RH for 24 hours, and perform the test with 2.0 g of this substance at 105°C for 3 hours: not more than 13%.

Residue on ignition: Not more than 2.5% (Method 2)

Paraffin

Definition

Paraffin is a mixture of solid hydrocarbons obtained by the polymerization of petroleum.

Description

It occurs as a colorless to white, more or less transparent crystalline mass, and it has a faint, characteristic odor.

Melting point: 70-110°C

Purity

- (1) Acidity or alkalinity

Melt 10 g of this substance by heating, add 10 mL of hot ethanol, shake and allow to stand: the ethanol layer is neutral.

- (2) Readily carbonizable substances

Take 5 g of this substance in a Nessler tube, melt on an oil bath at 110°C and add 5 mL of sulfuric acid (94.5- 95.5%). Heat on an oil bath at 110°C for 30 seconds: the sulfuric acid layer has no more color than that of the following control solution.

Control solution: To 3.0 mL of Ferric (II) Chloride Colorimetric Stock Solution, add 1.5 mL of Cobalt (I) Chloride Colorimetric Stock Solution and 0.5 mL of Copper Sulfate Colorimetric Stock Solution, and shake.

(3) Sulfur compounds

To 4.0 g of this substance, add 2 mL of ethanol (99.5) and 2 drops of a transparent sodium hydroxide solution (1 in 5) saturated with lead monoxide, heat at 110°C for 10 minutes with occasional shaking, and allow to cool: no dark color is produced.

(4) Heavy metals: Not more than 30 ppm (Method 3)

(5) Arsenic: Not more than 2 ppm (Method 2)

Residue on ignition: Not more than 0.05% (5.0 g, Method 1)

Paraffin Oil

Definition

Paraffin Oil is a mixture of liquid hydrocarbons obtained from petroleum.

Description

It is a colorless, clear, oily liquid having no fluorescence, and it is odorless or has a faint odor of petroleum while hot.

Specific gravity: d_{20}^{20} 0.81-0.91

Purity

(1) Acidity or alkalinity

Boil 10 mL of this substance with 10 mL of ethanol: the ethanol layer is neutral.

(2) Sulfur compounds

To 4.0 mL of this substance, add 2 mL of ethanol (99.5) and 2 drops of a transparent sodium hydroxide solution (1 in 5) saturated with lead monoxide, heat at 70°C for 10 minutes with occasional shaking, and allow to cool: no dark color is produced.

(3) Polynuclear aromatic hydrocarbons

Transfer 25 mL of this substance into a 100-mL separator using a 25-mL measuring cylinder, wash the measuring cylinder with 25 mL of n-hexane for ultraviolet-visible spectrophotometry, combine the washings with the liquid in the separator, and shake well. Shake this solution vigorously with 5.0 mL of dimethylsulfoxide for ultraviolet-visible spectrophotometry for 2 minutes, and allow to stand for 15 minutes. Transfer the lower layer into a 50-mL separator, add 2 mL of n-hexane for ultraviolet-visible spectrophotometry, shake vigorously for 2 minutes and allow to stand for 2 minutes. Transfer the lower layer into a glass-stoppered 10-mL centrifuge tube, centrifuge at the rate between 2500 and 3000 rpm for about 10 minutes. Transfer the clear solution so obtained into a cell, stopper tightly, and use this solution as the sample solution. Separately, transfer 25 mL of n-hexane for ultraviolet-visible spectrophotometry into another 50-mL separator, shake vigorously with 5.0 mL of dimethylsulfoxide for ultraviolet-visible spectrophotometry for 2 minutes, and allow to stand for 2 minutes. Transfer the lower layer into a glass-stoppered 10-mL centrifuge tube, centrifuge at the rate between 2500 and 3000 rpm for about 10 minutes. Transfer the clear solution so obtained into a cell, and stopper tightly. Immediately determine the absorbance of the sample solution using this solution as the blank: it is not more than 0.20 at the wavelength between 260 and 350 nm.

- (4) Heavy metals: Not more than 30 ppm (Method 3)
- (5) Arsenic: Not more than 2 ppm (Method 2)

Amorphous Propylene-Ethylene Copolymer

Definition

Amorphous Propylene-Ethylene Copolymer is a copolymer of propylene and ethylene. The mean molecular weight is 1000 to 10000.

Description

It occurs as a milky-white to light yellow, slightly viscous solid, and it is odorless or has a faint, characteristic odor.

It is practically insoluble in water, diethyl ether and ethanol, but slightly soluble in toluene and n-heptane.

Identification

Heat and compress this substance at 190°C to make a 50-100- μm film, and determine the infrared absorption spectrum of this substance as directed in the film method under Infrared Spectrophotometry: it exhibits absorption at the wave numbers of about 2960 cm^{-1} , 2850 cm^{-1} , 1460 cm^{-1} , 1380 cm^{-1} , 1156 cm^{-1} , 973 cm^{-1} and 730 cm^{-1} .

Purity

- (1) Clarity of solution

Dissolve 1 g of this substance in 100 mL of toluene at 80°C: the solution is clear.

- (2) Heavy metals: Not more than 10 ppm (Method 2)

Loss on drying: Not more than 1.0% (50 g, 160°C, 4 hours)

Residue on ignition: Not more than 0.1% (30 g, 900°C, 90 minutes)

Amorphous Propylene-Ethylene-Butene-1 Ternary Copolymer

Definition

Amorphous Propylene-Ethylene-Butene-1 Ternary Copolymer is a ternary copolymer of propylene, ethylene and butane-1. The mean molecular weight is 1000 to 10000.

Description

It occurs as a milky-white to light yellow, slightly viscous solid, and it is odorless or has a faint, characteristic odor.

It is practically insoluble in water, diethyl ether and ethanol, but slightly soluble in toluene and n-heptane.

Identification

Heat and compress this substance at 190°C to make a 50-100- μm film, and determine the infrared absorption spectrum of this substance as directed in the film method under Infrared Spectrophotometry: it exhibits absorption at the wave numbers of about 2960 cm^{-1} , 2850 cm^{-1} , 1460 cm^{-1} , 1380 cm^{-1} , 1156 cm^{-1} , 973 cm^{-1} , 760 cm^{-1} and 730 cm^{-1} .

Purity

- (1) Clarity of solution

Dissolve 1 g of this substance in 100 mL of toluene at 80°C: the solution is clear.

(2) Heavy metals: Not more than 10 ppm (Method 2)

Loss on drying: Not more than 1.0% (50 g, 160°C, 4 hours)

Residue on ignition: Not more than 0.1% (30 g, 900°C, 90 minutes)

Amorphous Propylene-Butene-1 Copolymer

Definition

Amorphous Propylene-Butene-1 Copolymer is a copolymer of propylene and butene-1. The mean molecular weight is 1000 to 10000.

Description

It occurs as a milky-white to light yellow, slightly viscous solid, and it is odorless or has a faint, characteristic odor.

It is practically insoluble in water, diethyl ether and ethanol, but slightly soluble in toluene and n-heptane.

Identification

Heat and compress this substance at 190°C to make a 50-100- μm film, and determine the infrared absorption spectrum of this substance as directed in the film method under Infrared Spectrophotometry: it exhibits absorption at the wave numbers of about 2960 cm^{-1} , 2850 cm^{-1} , 1460 cm^{-1} , 1380 cm^{-1} , 1156 cm^{-1} , 973 cm^{-1} and 760 cm^{-1} .

Purity

(1) Clarity of solution

Dissolve 1 g of this substance in 100 mL of toluene at 80°C: the solution is clear.

(2) Heavy metals: Not more than 10 ppm (Method 2)

Loss on drying: Not more than 1.0% (50 g, 160°C, 4 hours)

Residue on ignition: Not more than 0.1% (30 g, 900°C, 90 minutes)

Amorphous Polypropylene Resin

Definition

Amorphous Polypropylene Resin is a polymer of propylene. The mean molecular weight is 1000 to 10000.

Description

It occurs as a milky-white to light yellow, slightly viscous solid, and it is odorless or has a faint, characteristic odor.

It is practically insoluble in water, diethyl ether and ethanol, but slightly soluble in toluene and n-heptane.

Identification

Heat and compress this substance at 190°C to make a 50-100- μm film, and determine the infrared absorption spectrum of this substance as directed in the film method under Infrared Spectrophotometry: it exhibits absorption at the wave numbers of about 2960 cm^{-1} , 2850 cm^{-1} , 1460 cm^{-1} , 1380 cm^{-1} , 1156 cm^{-1} and 973 cm^{-1} .

Purity

(1) Clarity of solution

Dissolve 1 g of this substance in 100 mL of toluene at 80°C: the solution is clear.

(2) Heavy metals: Not more than 10 ppm (Method 2)

Loss on drying: Not more than 1.0% (50 g, 160°C, 4 hours)

Residue on ignition: Not more than 0.1% (30 g, 900°C, 90 minutes)

Emulsion of Rosin Denatured with Fumaric Acid

Definition

Emulsion of Rosin Denatured with Fumaric Acid is an emulsion obtained by the emulsification of rosin denatured with fumaric acid with emulsifying agent.

Description

It is a white liquid and it is odorless or has a faint, characteristic odor.

Identification

Determine the infrared absorption spectrum of this substance, previously dried at 105 °C for about 2 hours, as directed in the film method under Infrared Spectrophotometry: it exhibits absorption at the wave number of about 1700 cm⁻¹.

pH: 4.0-6.5

Purity

(1) Heavy metals: Not more than 10 ppm (Method 2)

(2) Arsenic: Not more than 2 ppm (Method 2)

Aromatic Denatured Terpene Resin

Definition

Aromatic Denatured Terpene Resin is a synthetic resin obtained by hydrogenating a copolymer of terpene hydrocarbon compound and aromatic hydrocarbon compound having a substituent.

Description

It occurs as a light yellow, translucent, bead-like or flaky, easily-breakable solid, and it is practically odorless. It is freely soluble in chloroform and toluene, but practically insoluble in water and ethanol.

Identification

Dissolve about 1 g of this substance in 5 mL of chloroform, apply lightly this solution on the disk, evaporate the chloroform to make a film, and determine the infrared absorption spectrum of this substance as directed in the film method under Infrared Spectrophotometry: it exhibits absorption at the wave numbers of about 2900 cm⁻¹, 1600 cm⁻¹, 1450 cm⁻¹ and 1375 cm⁻¹.

Acid value: Not more than 2.0 (Method 1)

Dissolve this substance in a mixture of toluene and ethanol (1:1). Use this solution for the test.

Heavy metals: Not more than 10 ppm (Method 2)

Loss on drying: Not more than 1% (1.0 g, 105°C, 4 hours)

Residue on ignition: Not more than 0.1% (10 g, 800°C)

Polyacrylamide Solution

Definition

Polyacrylamide Solution is a solution of copolymer of polyacrylamide.

Description

It is a light yellow, clear liquid, and it is odorless or has a faint, characteristic odor.

Identification

Determine the infrared absorption spectrum of this substance, previously dried at 105°C for about 2 hours, as directed in the film method under Infrared Spectrophotometry: it exhibits absorption at the wave numbers of about 3380 cm⁻¹, 1660 cm⁻¹, 1610 cm⁻¹ (amide), 1460 cm⁻¹ and 1130 cm⁻¹.

pH: 4.0-9.0

Purity

- (1) Heavy metals: Not more than 20 ppm (Method 2)
- (2) Arsenic: Not more than 2 ppm (Method 2)
- (3) Acrylic unreacted monomer: Not more than 1.5% (1.0 g)

Polyacrylamide-Polyvinyl Alcohol Copolymer Emulsion

Definition

Polyacrylamide-Polyvinyl Alcohol Copolymer Emulsion is a copolymer emulsion of polyvinyl alcohol and amide polyacrylate.

Description

It is a viscous, opaque liquid, and it is practically odorless.

Identification

- (1) Identification of polyvinyl alcohol
To 5 mL of this substance, add 1 drop of iodine TS: a dark blue or red color is produced. Separately, take 5 mL of this substance and add 10 mL of ethanol: a cotton-like precipitation is produced.
- (2) Identification of amide polyacrylate
Determine the infrared absorption spectrum of this substance, previously dried at 105°C for about 2 hours, as directed in the film method under Infrared Spectrophotometry: it exhibits absorption at the wave numbers of about 3380 cm⁻¹, 1660 cm⁻¹, 1610 cm⁻¹ (amide), 1460 cm⁻¹ and 1130 cm⁻¹.

Purity

- (1) Heavy metals: Not more than 20 ppm (Method 2)
- (2) Arsenic: Not more than 2 ppm (Method 2)
- (3) Acrylic unreacted monomer: Not more than 1.5% (1.0 g)

Polyester-Copolymer Polyester Bicomponent Fiber

Definition

Polyester-Copolymer Polyester Bicomponent Fiber is a polyester (polyethylene terephthalate)-core/copolymer polyester (polyethylene terephthalate/isophthalate copolymer polyester)-sheath bicomponent fiber.

Description

It occurs as colorless to white fibrous substances, and it is odorless.

Identification

- (1) Determine the infrared absorption spectrum of this substance as directed in the film method under Infrared Spectrophotometry: it exhibits absorption at the wave numbers of about 1720 cm^{-1} , 1580 cm^{-1} , 1500 cm^{-1} , 1410 cm^{-1} , 1260 cm^{-1} , 1100 cm^{-1} , 1015 cm^{-1} , 870 cm^{-1} and 725 cm^{-1} .
- (2) Place this substance near a flame. It melts and burns, and a black hard round ash remains.

Specific gravity: 1.37-1.38

Melting point: Polyester: 255°C - 260°C

Polyester copolymer: 110°C (softening point, observed with naked eye)

Purity

- (1) Heavy metals: Not more than 20 ppm (Method 2)
- (2) Arsenic: Not more than 2 ppm (Atomic Absorption Spectrophotometry)

Residue on ignition: Not more than 4% (Method 2)

Polyethylene Terephthalate Resin (PET)

Definition

Polyethylene Terephthalate Resin (PET) is a polyethylene terephthalate resin obtained by the esterification or transesterification of terephthalic acid or dimethyl terephthalate and ethylene glycol, followed by polycondensation.

Description

It occurs as translucent powder or granules, and it is practically odorless.

Identification

Determine the infrared absorption spectrum of this substance as directed in the film method under Infrared Spectrophotometry: it exhibits absorption at the wave numbers of about 1720 cm^{-1} , 1580 cm^{-1} , 1250 cm^{-1} , 1100 cm^{-1} , 1015 cm^{-1} , 870 cm^{-1} and 725 cm^{-1} .

Specific gravity: 1.35-1.39

Melting point: 200 - 260°C

Purity

- (1) Heavy metals: Not more than 20 ppm (Method 2)
- (2) Arsenic: Not more than 2 ppm (Method 2)

Residue on ignition: Not more than 0.1% (5.0 g, Method 1)

Polyethylene Terephthalate Fiber

Definition

Polyethylene Terephthalate Fiber is a polyethylene terephthalate fiber obtained by the esterification or transesterification of terephthalic acid or dimethyl terephthalate and ethylene glycol, followed by polycondensation.

Description

It occurs as colorless to white fibrous substances, and it is odorless.

Identification

- (1) Determine the infrared absorption spectrum of this substance as directed in the film method under Infrared Spectrophotometry: it exhibits absorption at the wave numbers of about 1720 cm^{-1} , 1580 cm^{-1} , 1250 cm^{-1} , 1100 cm^{-1} , 1015 cm^{-1} , 870 cm^{-1} and 725 cm^{-1} .
- (2) Place this substance near a flame. It melts and burns, and a black hard round ash remains.

Specific gravity: 1.38-1.39

Melting point: 250-260°C

Purity

- (1) Heavy metals: Not more than 20 ppm (Method 2)
- (2) Arsenic: Not more than 2 ppm (Atomic Absorption Spectrophotometry)

Residue on ignition: Not more than 2.5% (Method 2)

Polyethylene Terephthalate/Polyethylene Bicomponent Fiber

Definition

Polyethylene Terephthalate/Polyethylene Bicomponent Fiber is a polyester (polyethylene terephthalate)-core/polyethylene-sheath bicomponent fiber.

Description

It occurs as colorless to white fibrous substances, and it is odorless.

Identification

Determine the infrared absorption spectrum as directed in the film method under Infrared Spectrophotometry: it exhibits absorption at the wave numbers of about 2980 cm^{-1} , 2910 cm^{-1} , 1720 cm^{-1} , 1580 cm^{-1} , 1450 cm^{-1} , 1250 cm^{-1} , 1100 cm^{-1} , 1015 cm^{-1} , 870 cm^{-1} and 725 cm^{-1} .

Specific gravity: 1.07-1.37

Melting point: Polyester: 250-260°C

Polyethylene: 115-135°C

Purity

- (1) Heavy metals: Not more than 20 ppm (Method 2)
- (2) Arsenic: Not more than 2 ppm (Atomic Absorption Spectrophotometry)

Residue on ignition: Not more than 4% (Method 2)

Polyethylene Oxide

Definition

Polyethylene Oxide is a water-soluble polymer obtained by the ring-opening polymerization of ethylene oxide. The mean molecular weight is 2,000,000 to 10,000,000.

Description

It occurs as a white powder, and it is odorless or has a faint, characteristic odor.

Identification

To 0.5 g of Polyethylene Oxide add 10 mL of water and 5 mL of ammonium thiocyanate-cobalt (II) nitrate TS, shake well, further add 5 mL of chloroform, shake well, and allow to stand: a blue color develops in the chloroform layer.

Viscosity

The viscosity of a solution (1 in 200) is 100-1000 mPa·s. (Brookfield type viscometer, No. 2, 12 rotations, 25°C, constant)

Purity

- (1) Heavy metals: Not more than 20 ppm (Method 2)
- (2) Arsenic: Not more than 2 ppm (Method 2)

Loss on drying: Not more than 4.0% (2.0 g, 105°C, 3 hours)

Residue on ignition: Not more than 5.0% (Method 1)

Polyethylene Resin

Definition

Polyethylene Resin is a polyethylene resin obtained by the polymerization of ethylene.

Description

It occurs as translucent powder or granules, and it is practically odorless.

Identification

Determine the infrared absorption spectrum as directed in the film method under Infrared Spectrophotometry: it exhibits absorption of polymer n-paraffin homologues.

Specific gravity: 0.85-1.00

Melting point: 90-140°C

Purity

- (1) Clarity and color of solution
Dissolve 1.0 g of this substance in 50 mL of xylene by heating: the solution is colorless and clear.
- (2) Heavy metals: Not more than 20 ppm (Method 2)
- (3) Arsenic: Not more than 2 ppm (Method 2)

Residue on ignition: Not more than 0.1% (5.0 g, Method 1)

Polyethylene Fiber

Definition

Polyethylene Fiber is a fiber of polyethylene obtained by the polymerization of ethylene.

Description

It occurs as colorless to white fibrous substances, and it is odorless.

Identification

- (1) Determine the infrared absorption spectrum as directed in the film method under Infrared Spectrophotometry: it exhibits absorption at the wave numbers of about 2900 cm⁻¹, 1470 cm⁻¹, 1370 cm⁻¹,

740 cm^{-1} and 720 cm^{-1} .

- (2) Place this substance near a flame. It melts and burns with fumes emitting an odor of paraffin. A gray hard bead-like ash remains.

Specific gravity: 0.93-0.96

Melting point: 120-135°C

Purity

- (1) Heavy metals: Not more than 20 ppm (Method 2)
- (2) Arsenic: Not more than 2 ppm (Method 2)

Residue on ignition: Not more than 2.5% (Method 2)

Polyethylene/Polypropylene Bicomponent Fiber

Definition

Polyethylene/Polypropylene Bicomponent Fiber is a polypropylene-core/polyethylene-sheath or side-by-side bicomponent fiber.

Description

It occurs as colorless to white fibrous substances, and it is odorless.

Identification

- (1) Determine the infrared absorption spectrum as directed in the film method under Infrared Spectrophotometry: it exhibits absorption at the wave numbers of about 2980 cm^{-1} , 2930 cm^{-1} , 2830 cm^{-1} , 1465 cm^{-1} , 1455 cm^{-1} , 1375 cm^{-1} , 1255 cm^{-1} , 1165 cm^{-1} , 995 cm^{-1} , 970 cm^{-1} , 840 cm^{-1} , 810 cm^{-1} , 740 cm^{-1} and 725 cm^{-1} .
- (2) Place this substance near a flame. It melts and burns with fumes emitting an odor of paraffin. A gray hard bead-like ash remains.

Specific gravity: 0.91-1.01

Melting point: Polypropylene: 160-170°C

Polyethylene: 115-135°C

Purity

- (1) Heavy metals: Not more than 20 ppm (Method 2)
- (2) Arsenic: Not more than 2 ppm (Method 2)

Residue on ignition: Not more than 4% (Method 2)

Polyvinyl Chloride Fiber (PVC Fiber)

Definition

Polyvinyl Chloride Fiber (PVC Fiber) is a fiber of polyvinyl chloride obtained by the suspension polymerization of vinyl chloride.

Description

It occurs as colorless to white fibrous substances, and it is odorless.

Identification

- (1) Determine the infrared absorption spectrum of this substance as directed in the potassium bromide disk method under Infrared Spectrophotometry: it exhibits absorption at the wave numbers of about 2950 cm⁻¹, 1420 cm⁻¹, 1240 cm⁻¹, 1070 cm⁻¹, 960 cm⁻¹ and 700 cm⁻¹.
- (2) When burned, it softens and shrinks with fume and becomes a black block coal.

Specific gravity: 1.39

Melting point: 200-210°C

Purity

Vinyl chloride

Take 1.0 g of this substance in a 20-mL volumetric flask. Add about 10 mL of tetrahydrofuran for gas chromatography, dissolve by occasional shaking in a cold place, add tetrahydrofuran for gas chromatography, previously cooled, to make 20 mL while cooling, and use this solution as the sample solution. Perform the test with 2 µL each of the sample solution and Standard Vinyl Chloride Solution as directed under Gas Chromatography according to the following conditions. Determine the peak heights, H_t and H_s, of vinyl chloride of respective solutions: H_t is not higher than H_s.

Operating conditions

Detector: Hydrogen flame-ionization detector

Column: A column about 3 mm in inside diameter and 2 or 3 m in length, packed with siliceous earth for gas chromatography (150 to 180 µm) coated with polypropylene glycol for gas chromatography in 10-15%

Column temperature: A constant temperature of about 60-70°C

Carrier gas: Nitrogen

Flow rate: Adjust the flow rate so that the retention time of vinyl chloride is about 1.5 minutes.

Selection of column: Proceed with 2 µL of Standard Vinyl Chloride Solution under the above operating conditions. Use a column from which vinyl chloride and ethanol are eluted in that order, with a good resolution between their peaks.

Detection sensitivity: Adjust it so that the peak height of vinyl chloride obtained from 2 µL of the Standard Vinyl Chloride Solution is 50 to 70 mm.

Loss on drying: Not more than 1.0% (1.0 g, 105°C, 2 hours)

Residue on ignition: Not more than 2.5% (Method 2)

Polyvinyl Alcohol

Definition

Polyvinyl Alcohol is a polymer obtained by saponifying polyvinyl acetate and is expressed as -[CH₂-CHOH]_n-[CH₂-CHOCOCH₃]_m-. The viscosity of this substance is expressed as mPa·s. Usually, it is between 2 mPa·s and 100 mPa·s.

Description

It occurs as colorless to pale yellowish white granules, powder or fibrous substances, and it is odorless or has a faint odor of acetic acid.

It is practically insoluble in ethanol, diethyl ether, and chloroform.

To this substance add water, and heat: A clear, viscous solution is obtained.

It is hygroscopic.

Identification

- (1) Dissolve 0.5 g of this substance in 10 mL of water by heating, cool, add 1 drop of iodine TS to 5 mL of this solution and allow to stand: a dark red to blue color develops.
- (2) Dissolve 0.01 g of this substance in 100 mL of water by heating, cool, add 1 drop of iodine TS to 5 mL of this solution, mix, and add 5 mL of a solution of boric acid (1 in 25): a blue color develops.
- (3) To 2 mL of the solution obtained in (1), add 5 mL of ethanol: a white cotton-like precipitate is produced.

Viscosity: 85-115% of the labeled value (mPa·s)

Take 4.000 g of this substance, previously dried, add 95 mL of water, allow to stand for 30 minutes and dissolve by heating under a reflux condenser for 2 hours while stirring. After cooling, add water to make 100.0 g, and mix. Allow to stand still to remove bubbles and perform the test at $20 \pm 0.1^\circ\text{C}$ as directed in Method 1.

pH: 5.0 - 8.0 (1 in 25)

Saponification value: Not less than 70 mol%.

Weigh accurately the amount as directed in Table 1 according to the estimated saponification value, previously dried, transfer into a glass-stoppered conical flask, add 100 mL of water, and dissolve by heating while stirring for 2 hours. After cooling, add exactly 25 mL of 0.1 mol/L or 0.5 mol/L sodium hydroxide VS according to Table 1, stopper tightly, and allow to stand for 2 hours. Then add exactly 25 mL of sulfuric acid at the same concentration as that of sodium hydroxide VS, shake well, and titrate with 0.1 mol/L or 0.5 mol/L sodium hydroxide VS according to Table 1 (indicator: 3 drops of phenolphthalein TS). Perform a blank determination in the same manner.

$$\text{Saponification value (mol\%): } 100 - \frac{44.05A}{60.05 - 0.42A}$$

$$A = \frac{0.6005 \times (a-b)FD}{\text{Amount (g) of sample}}$$

a: Volume (mL) of 0.1 mol/L or 0.5 mol/L sodium hydroxide VS consumed

b: Volume (mL) of 0.1 mol/L or 1.0 mol/L sodium hydroxide VS consumed in the blank determination

F: Molarity factor of 0.1 mol/L or 0.5 mol/L sodium hydroxide VS

D: Concentration of sodium hydroxide VS (0.1 mol/L or 0.5 mol/L)

Table 1 Estimated saponification value, and amount of the sample and specified solution for use

Estimated saponification value mol%	Amount of sample G	Solution specified for use	
		Concentration mol/L	Used amount mL
Not less than 97	3	0.1	25.00

Not less than 90, less than 97	3	0.5	25.00
Not less than 80, less than 90	2	0.5	25.00
Not less than 70, less than 80	1	0.5	25.00

Purity

- (1) Clarity and color of solution

To 1.0 g of this substance, add 20 mL of water, disperse by stirring well, heat for not less than 2 hours while stirring and cool: the solution is colorless and clear.

- (2) Heavy metals: Not more than 10 ppm (2.0 g, Method 2, Standard Lead Solution 2.0 mL)
(3) Arsenic: Not more than 2 ppm (Method 2)

Loss on drying: Not more than 6.0% (1.0 g, 105°C, 3 hours)

Residue on ignition: Not more than 2% (Method 1)

Polypropylene Copolymer Fiber

Definition

Polypropylene Copolymer Fiber is a fiber of propylene-ethylene copolymer obtained by copolymerizing propylene and ethylene.

Description

It occurs as colorless to white fibrous substances, and it is odorless.

Identification

Determine the infrared absorption spectrum as directed in the film method under Infrared Spectrophotometry: it exhibits absorption at the wave numbers of about 2950 cm⁻¹, 2920 cm⁻¹, 2830 cm⁻¹, 1455 cm⁻¹, 1375 cm⁻¹, 1255 cm⁻¹, 1165 cm⁻¹, 970 cm⁻¹, 840 cm⁻¹ and 720 cm⁻¹.

Specific gravity: 0.89 - 0.90

Melting point: 148°C

Purity

- (1) Heavy metals: Not more than 20 ppm (Method 2)
(2) Arsenic: Not more than 2 ppm (Method 2)

Residue on ignition: Not more than 4% (Method 2)

Polypropylene/Copolymer Polypropylene Bicomponent Fiber

Definition

Polypropylene/Copolymer Polypropylene Bicomponent Fiber is a polypropylene-core/polypropylene copolymer (propylene-ethylene copolymer)-sheath or side-by-side bicomponent fiber.

Description

It occurs as colorless to white fibrous substances, and it is odorless.

Identification

- (1) Determine the infrared absorption spectrum as directed in the film method under Infrared Spectrophotometry: it exhibits absorption at the wave numbers of about 2980 cm⁻¹, 2940 cm⁻¹, 2830 cm⁻¹,

1460 cm^{-1} , 1380 cm^{-1} , 1255 cm^{-1} , 1165 cm^{-1} , and 710 cm^{-1} .

- (2) Place this substance near a flame. It melts and burns with fumes emitting an odor of paraffin. A gray hard bead-like ash remains.

Specific gravity: 0.91-0.94

Melting point: Polypropylene: 160-170°C

Copolymer polypropylene: 115-148°C

Purity

- (1) Heavy metals: Not more than 20 ppm (Method 2)
(2) Arsenic: Not more than 2 ppm (Method 2)

Residue on ignition: Not more than 4% (Method 2)

Polypropylene Resin (PP)

Definition

Polypropylene Resin (PP) is a polypropylene resin obtained by polymerizing propylene.

Description

It occurs as translucent powder or granules, and it is practically odorless.

Identification

Determine the infrared absorption spectrum as directed in the film method under Infrared Spectrophotometry: it exhibits absorption at the wave numbers of about 2930 cm^{-1} , 2830 cm^{-1} , 1455 cm^{-1} , 1375 cm^{-1} , 1255 cm^{-1} , 1165 cm^{-1} , 995 cm^{-1} , 970 cm^{-1} , 840 cm^{-1} and 810 cm^{-1} .

Specific gravity: 0.89-0.94

Melting point: 150-170°C

Purity

- (1) Clarity and color of solution
Dissolve 1 g of this substance in 50 mL of xylene by heating: the solution is colorless and clear.
(2) Heavy metals: Not more than 20 ppm (Method 2)
(3) Arsenic: Not more than 2 ppm (Method 2)

Residue on ignition: Not more than 0.1% (5.0 g, Method 1)

Polypropylene Fiber

Definition

Polypropylene Fiber is a fiber obtained by the polymerization of propylene.

Description

It occurs as colorless to white fibrous substances, and it is odorless.

Identification

- (1) Determine the infrared absorption spectrum as directed in the film method under Infrared Spectrophotometry: it exhibits absorption at the wave numbers of about 2930 cm^{-1} , 2830 cm^{-1} , 1455 cm^{-1} , 1375 cm^{-1} , 1255 cm^{-1} , 1165 cm^{-1} , 995 cm^{-1} , 970 cm^{-1} , 840 cm^{-1} and 810 cm^{-1} .

- (2) Place this substance near a flame. It melts and burns with fumes emitting an odor of paraffin. A gray hard bead-like ash remains.

Specific gravity: 0.89-0.94

Melting point: 160-170°C

Purity

- (1) Heavy metals: Not more than 20 ppm (Method 2)
(2) Arsenic: Not more than 2 ppm (Method 2)

Residue on ignition: Not more than 2.5% (Method 2)

Solution of Petroleum Resin Denatured with Maleic Acid

Definition

Solution of Petroleum Resin Denatured with Maleic Acid is obtained by adding an aqueous solution of potassium hydroxide to warmed maleinized petroleum resin and maleinized rosin, followed by neutralization while well stirring, then emulsification and dispersion by adding water, cooling and filtration.

Description

It is a pale yellow-brown, translucent liquid, and it has a characteristic odor.

Identification

Dissolve 1.0 g of this substance in 5 mL of water, neutralize with 0.2 mL of hydrochloric acid, add 10 mL of diethyl ether and stir. Take the ether layer, evaporate the solvent and determine the infrared absorption spectrum as directed in the potassium bromide disk method under Infrared Spectrophotometry: it exhibits absorption at the wave numbers of about 1860 cm^{-1} , 1780 cm^{-1} , 1700 cm^{-1} , 720 cm^{-1} and 700 cm^{-1} .

pH: 9.5-10.5 (1 in 6)

Purity

- (1) Heavy metals: Not more than 10 ppm (Method 2)
(2) Arsenic: Not more than 2 ppm (Method 2)

Solution of Rosin Denatured with Maleic Acid

Definition

Solution of Rosin Denatured with Maleic Acid is an aqueous solution of the alkali metal salt of rosin denatured with maleic acid.

Description

It is a brown, clear liquid, and it has a characteristic odor of rosin.

Identification

Determine the infrared absorption spectrum of this substance, previously dried at 105 °C for about 2 hours, as directed in the film method under Infrared Spectrophotometry: it exhibits absorption at the wave numbers of about between 3000 cm^{-1} and 2800 cm^{-1} , 1570 cm^{-1} , and 700 cm^{-1} .

pH: 9.0-11.0

Purity

- (1) Heavy metals: Not more than 10 ppm (Method 2)
- (2) Arsenic: Not more than 2 ppm (Method 2)

α -Methylstyrene-group Resin

Definition

α -Methylstyrene-group Resin is an oligomer obtained by the polymerization of α -methylstyrene monomer (50-90%) and styrene monomer (10-50%) using boron trifluoride as a catalyst. The mean molecular weight is 600 to 5000.

Description

It occurs as a white, slightly viscous solid, and it is freely soluble in acetone and toluene, but insoluble in water and methanol.

Identification

Dissolve about 4.0 g of this substance in 100 mL of carbon tetrachloride and inject the solution into a fixed cell of sodium chloride. Perform the test as directed in the Solution method under Infrared Spectrophotometry: it exhibits absorption at the wave numbers of about 2970 cm^{-1} and 2930 cm^{-1} .

Purity

- (1) Clarity of solution

To 1 g of this substance, add 100 mL of toluene and heat on a water bath: the solution is clear.

- (2) Heavy metals: Not more than 50 ppm (0.5 g, Method 2, Standard Lead Solution 2.5 mL)

Loss on drying: Not more than 1.0% (1.0 g, 105°C , 4 hours)

Residue on ignition: Not more than 0.1% (1.0 g, $450\text{-}550^{\circ}\text{C}$)

Flocculent Pulp

Definition

Flocculent Pulp is a flocculent chemical pulp.

Description

- (1) It is white in color, odorless, and contains no foreign matter.
- (2) It does not remarkably contain fiber mass.

Purity

- (1) Lignin

Dissolve 0.1 g of phloroglucin in 15 mL of hydrochloric acid, add water to make 20 mL and drop onto this substance: no marked pink or red color develops.

- (2) Coloring matter

Immerse 10 g of this substance in 100 mL of ethanol, press out, transfer 50 mL of the extract into a Nessler tube and observe downward: a yellow color may develop but neither blue nor green color develops.

- (3) Acidity or alkalinity

To 10 g of this substance, add 100 mL of freshly boiled and cooled water and allow to cool. To 25 mL of

the solution, add 3 drops of phenolphthalein TS: no red color develops. Separately, to 25 mL of the same solution, add 1 drop of methyl orange TS: no red color develops.

(4) Fluorescence

Irradiate this substance with ultraviolet rays (main wavelength: 365 nm) in a dark place: it shows neither marked fluorescence nor fluorescence by contamination.

(5) Sedimentation velocity

Prepare a test basket, weighing about 3 g from copper wire 0.4 mm in diameter (No. 26) in the form of a cylinder 50 mm in diameter and 80 mm in depth, with 20-mm intervals between the wires. Place 5.0 g of this substance in the test basket, drop the basket on its side gently into the water about 200 mm in depth at ordinary temperature from the height of about 10 mm above the water surface: the basket sinks in water within 8 seconds.

Total ash: Not more than 0.65% (5.0 g)

Sorbitan Monolaurate

Definition

Sorbitan Monolaurate consists mainly of laurate monoester of sorbitan.

Description

It is a pale yellow to yellow-brown liquid, and it has a faint, characteristic odor.

Identification

- (1) To 0.5 g of this substance, add 5 mL of ethanol, dissolve by heating on a water bath, add 5 mL of dilute sulfuric acid, and heat further for 30 minutes and cool: oily drops or a white to yellowish white solid is precipitated. This separated oily drops or solid dissolves when shaken with 5 mL of diethyl ether.
- (2) Shake 2 mL of the separately oily drops or solid in (1) with 2 mL of freshly prepared catechol solution (1 in 10), then with 5 mL of sulfuric acid: a red to red-brown color develops.
- (3) Saponify 5 g of this substance using the saponification method and completely evaporate ethanol. Dissolve the residue in 50 mL of water, acidify with hydrochloric acid (indicator: methyl orange TS), and extract the residue with 30 mL of diethyl ether twice. Combine the ether layers, wash with 20 mL portions of water until the washings become neutral, and evaporate the ether on a water bath: the acid value of the residue is between 260 to 280 (0.5 g, Method 1). Use 50 mL of the 0.5 mol/L ethanol solution of potassium hydroxide for saponification.

Acid value: Not more than 13 (2.0 g, Method 2)

Saponification value: 155-174

Purity

- (1) Heavy metals: Not more than 20 ppm (Method 2)
- (2) Arsenic: Not more than 2 ppm (Method 2)

Loss on drying: Not more than 3.0% (5.0 g, 105°C, 1 hour)

Residue on ignition: Not more than 1.0% (3.0 g, Method 3)

Cotton

Definition

Cotton is cotton wool adherent to seeds of raw cotton.

Description

- (1) It is white in color, odorless, and contains no foreign matter.
- (2) It does not remarkably contain broken pieces of pericarp and seed, or nep.

Identification

It is soluble in ammonium copper TS and insoluble in ethanol.

Purity

- (1) Coloring matter

Immerse 10 g of this substance in 100 mL of ethanol, press out, transfer 50 mL of the extract into a Nessler tube and observe downward: a yellow color may develop but neither blue nor green color develops.

- (2) Acidity or alkalinity

To 10 g of this substance, add 100 mL of freshly boiled and cooled water and allow to cool. To 25 mL of the solution, add 3 drops of phenolphthalein TS: no red color develops. Separately, to 25 mL of the same solution, add 1 drop of methyl orange TS: no red color develops.

- (3) Fluorescence

Irradiate this substance with ultraviolet rays (main wavelength: 365 nm) in a dark place: it shows neither marked fluorescence nor fluorescence by contamination.

Total ash: Not more than 0.25% (5.0 g)

Aluminum Sulfate (Solution)

Definition

Aluminum Sulfate (Solution) is an aqueous solution containing not less than 8.0% and not more than 8.2% of aluminum sulfate $[\text{Al}_2(\text{SO}_4)_3 \cdot 18\text{H}_2\text{O}]$.

Description

It is a colorless to light yellow-brown, clear liquid, and it is odorless.

Identification

- (1) It responds to the Qualitative Tests for aluminum salt.
- (2) It responds to the Qualitative Tests (1) and (2) for sulfate.

pH: 3.0-4.0 (2 w/v% solution of this substance)

Purity

- (1) Iron

Transfer 1.0 g of this substance into a Nessler tube, add 6 mL of dilute nitric acid and water to make 20 mL. Add 0.05 g of ammonium persulfate and 5 mL of ammonium thiocyanate TS, shake, add 15 mL of n-butanol and shake vigorously for 30 seconds: the n-butanol layer has no more color than the following control solution.

Control solution: Using 2.0 mL of Standard Iron Solution instead of this substance, perform the test in the same manner.

- (2) Heavy metals: Not more than 10 ppm (Method 1)
- (3) Arsenic: Not more than 2 ppm (0.40 g, Method 1)

Flocculent Rayon

Definition

Flocculent Rayon is flocculent regenerated fiber made from plant-based fibers.

Description

It is white in color, odorless, and contains no foreign matter.

Identification

It is soluble in sulfuric acid. It swells with ammonium copper TS and then dissolves.

Purity

- (1) Coloring matter

Immerse 10 g of this substance in 100 mL of ethanol, press out, transfer 50 mL of the extract into a Nessler tube and observe downward: a yellow color may develop but neither blue nor green color develops.

- (2) Acidity or alkalinity

To 10 g of this substance, add 100 mL of freshly boiled and cooled water and allow to cool. To 25 mL of the solution, add 3 drops of phenolphthalein TS: no red color develops. Separately, to 25 mL of the same solution, add 1 drop of methyl orange TS: no red color develops.

- (3) Fluorescence

Irradiate this substance with ultraviolet rays (main wavelength: 365 nm) in a dark place: it shows neither marked fluorescence nor fluorescence by contamination.

- (4) Sedimentation velocity

Prepare a test basket, weighing about 3 g from copper wire 0.4 mm in diameter (No. 26) in the form of a cylinder 50 mm in diameter and 80 mm in depth, with 20-mm intervals between the wires. Place 5.0 g of this substance in the test basket, drop the basket on its side gently into the water about 200 mm in depth at ordinary temperature from the height of about 10 mm above the water surface: the basket sinks in water within 8 seconds..

Total ash: Not more than 0.25% (5.0 g)

Not more than 1.2% (5.0 g) (delustered)

Rayon Fiber

Definition

Rayon Fiber is cellulose fiber obtained by regenerating cellulose using the viscose method.

Description

It occurs as colorless to light yellow fibrous substances, and it is practically odorless.

Identification

- (1) Determine the infrared absorption spectrum as directed in the potassium bromide disk method under Infrared Spectrophotometry: it exhibits absorption at the wave numbers of about 2900 cm^{-1} , 1650 cm^{-1} and 890 cm^{-1} .
- (2) Burn this substance: it emits an odor of burning paper, and the residual ash is thin and has a black or gray color.
- (3) It is soluble in ammonium copper TS.

Specific gravity: 1.50-1.52

Melting point: 260-300°C (with decomposition)

Purity

- (1) Heavy metals: Not more than 20 ppm (Method 2)
- (2) Arsenic: Not more than 2 ppm (Method 2)

Loss on drying: Not more than 11.0% (2.0 g, 105°C, 3 hours)

Residue on ignition: Not more than 2.5% (Method 2)

Part 2 - Colorants

Silicon Dioxide

- C.I. Acid Blue 9 (Blue No. 205)**
- C.I. Acid Blue 74 (Blue No. 2)**
- C.I. Acid Red 51 (Red No. 3)**
- C.I. Direct Yellow 12**
- C.I. Direct Orange 26**
- C.I. Direct Violet 51**
- C.I. Direct Blue 1**
- C.I. Direct Blue 86**
- C.I. Direct Blue 106**
- C.I. Direct Blue 203**
- C.I. Direct Red 23**
- C.I. Direct Red 31**
- C.I. Direct Red 80**
- C.I. Direct Red 81**
- C.I. Direct Red 227**
- C.I. Vat Blue 1 (Blue No. 201)**
- C.I. Pigment Yellow 1 (Yellow No. 401)**
- C.I. Pigment Yellow 12 (Yellow No. 205)**
- C.I. Pigment Yellow 14**
- C.I. Pigment Yellow 83**
- C.I. Pigment Orange 13 (Orange No. 204)**
- C.I. Pigment Green 7**
- C.I. Pigment Violet 19**
- C.I. Pigment Violet 23**
- C.I. Pigment Blue 15 (Blue No. 404)**
- C.I. Pigment Blue 27 (Iron Blue)**
- C.I. Pigment Brown 6 (Iron Oxide Brown)**
- C.I. Pigment Brown 24 (Chrome Titan Yellow)**
- C.I. Pigment Black 7 (Carbon Black)**
- C.I. Pigment White 4 (Zinc Oxide)**
- C.I. Pigment White 6 (Titanium Dioxide)**
- C.I. Pigment White 18 (Calcium Carbonate)**
- C.I. Pigment White 19 (Kaolin)**
- C.I. Pigment White 21 (Barium Sulfate)**
- C.I. Pigment Red 22 (Red No. 404)**
- C.I. Pigment Red 48 (Red No. 405)**
- C.I. Pigment Red 57 (Red No. 201)**

C.I. Pigment Red 57-1 (Red No. 202)

C.I. Pigment Red 166

C.I. Food Blue 2 (Blue No.1)

C.I. Basic Violet 3

C.I. Reactive Orange 16

C.I. Reactive Black 5

C.I. Reactive Blue 21

C.I. Reactive Blue 27

C.I. Reactive Blue 28

C.I. Reactive Blue 38

C.I. Reactive Red 21